

Installation Manual

For AC Electric Thruster Models

SAC750, SAC900, SAC950, SAC1100, SAC1200,
SAC1300, SAC1400



Installation Manual

- Warnings and safety3
- Responsibility of the installer3
- Product dimensions 4
- Measurements, PDC 5
- Measurements, VFD 6
- Product specifications 7
- Positioning of the tunnel / thruster 8
- Tunnel length 9
- Tunnel installation in sailboats 10
- Water deflection 11
- Tunnel ends 12
- Tunnel installation 13- 14
- Stern tunnel installation 15
- Gearleg & motor bracket installation 16
- Propeller installation 19
- Motor support, horizontal installation 20
- Motor support, vertical installation 20
- Motor dimensions 21
- Motor installation 22
- Oil tank installation 24
- VFD mechanical and electrical installation 25
- Recomended motor cables 25
- Power cable dimensions 26
- Electrical diagrams 27
- PDC 301 35
- Startup and commissioning 36
- Functions and operation 37
- S-link system description 38
- Control panel cable installation 39
- Control panel installation 40
- Checklist for AC thrusters 41
- Service and support 42
- Product spare parts and additional resources 42
- Patents 42
- Warranty statement 43

It is essential to follow all instructions within this document to avoid potential personal injury, death, or damage to existing products in the vessel, the vessel's hull integrity, and including this product during installation or operation. Failure to follow instructions within this document will render all warranties given by Sleipner Motor as VOID.

Warnings and situations requiring extra caution are outlined in the documentation. Take extra consideration when warnings are outlined.

WARNING

Indicates a hazardous situation which, if not avoided, could result in death or serious injury.

CAUTION

Indicates a hazardous situation which, if not avoided, could result in minor or moderate injury or damage to the product.

Responsibility of the installer

General:

- The installer must read this document to ensure necessary familiarity with the product before installation.
- Directions outlined in this document cannot be guaranteed to comply with all international and national regulations, including but not limited to health and safety procedures. It is the installers responsibility to adhere to all applicable international and national regulations when installing Sleipner products.
- This document contains general installation guidelines intended to support experienced installers. Contact professional installers familiar with the vessel, Sleipner products and applicable regulations if assistance is required.
- If local regulation requires any electrical work to be performed by a licensed professional, seek a licensed professional.
- When planning the installation of Sleipner products, ensure easy access to the products for future service and inspection requirements.

MC_0038

For Sleipner thruster systems:

- Do not install the thruster system in any position that requires modification of hull stiffeners or stringers. This might jeopardize the hull integrity. Consult with the boat builder to see if this can be done safely if absolutely necessary.
- Never run the thruster out of water. The propeller will reach extremely high speed, damaging the thruster.
- The thruster motor must be handled with care. Do not rest the motor on its drive shaft, as its weight can damage it.

MC_0425

For on-board electric motor driven systems:

- Ensure motors installed in small compartments are dry and well-ventilated to allow the electric motor to cool.
- The electric motor, components, and cables must be mounted to remain dry.
- The electric motor can reach over 100°C before activating the temperature switch. Any loose items near the thruster motor are a potential fire hazard and can cause short-circuiting.
- The thruster power supply circuit must include the recommended sized fuse and a battery isolation switch.
- Avoid running cables near any heat sources since this might damage the insulation. Broken insulation could potentially lead to hazards and damage products.

MC_0031

Sleipner S-Link™ Systems

- Only Sleipner S-Link™ products or authorized third-party control equipment may be connected directly to the S-Link™ bus.
- Non-authorized third-party equipment must always be connected through a Sleipner interface product.
- Connecting unauthorized equipment directly to the S-Link™ bus will void all warranties for connected Sleipner products.
- If third-party control equipment is interfaced to the S-Link™ bus through a Sleipner interface product, at least one Sleipner control panel must be installed to enable efficient system diagnostics and troubleshooting.

MC_0105

Measurement code	Description	SAC750 513-I		SAC900 513-I		SAC900 513-C		SAC1100 513-I		SAC1100 513-C		SAC950 610-I		SAC1100 610-I		SAC1200 610-C		SAC1300 610-I		SAC1400 610-I/C	
		mm	inch	mm	inch	mm	inch	mm	inch	mm	inch	mm	inch	mm	inch	mm	inch	mm	inch	mm	inch
ID	Internal tunnel diameter	513	20.2	513	20.2	513	20.2	513	20.2	513	20.2	610	24.02	610	24.02	610	24.02	610	24.02	610	24.02
T (min)	Tunnel thickness min.	12	.5	12	.5	12	.5	12	.5	12	.5	14	.6	14	.6	14	.6	14	.6	14	.6
T (max)	Tunnel thickness max.	22	.9	22	.9	22	.9	22	.9	22	.9	24	.9	24	.9	24	.9	24	.9	24	.9
TL	Minimum tunnel length	750	29.5	750	29.5	750	29.5	750	29.5	750	29.5	750	29.5	750	29.5	750	29.5	750	29.5	750	29.5
TL (recommended)	Recommended tunnel length	1000	39.4	1000	39.4	1000	39.4	1000	39.4	1000	39.4	1000	39.4	1000	39.4	1000	39.4	1000	39.4	1000	39.4
WD	Minimum recommended water depth.	800	31.5	800	31.5	800	31.5	900	35.5	900	35.5	900	35.5	900	35.5	900	35.5	900	35.5	900	35.5
H	Actual dimension will vary depending on tunnel outside diameter	1080	42.5	1195	47	1195	47	1195	47	1305	51.4	1190	46.9	1235	48.6	1305	51.4	1305	51.4	1305	51.4
W		396	15.6	449	17.7	449	17.7	449	17.7	495	19.5	449	17.7	495	19.5	555	22	555	22	555	22
L		496	19.5	563	22.2	563	22.2	563	22.2	642	25.3	563	22.2	660	26.0	712	28	712	28	712	28
(av) Vertical	Gear center to the motor flange	728	28.7	758	29.8	758	29.8	758	29.8	758	29.8	805	31.7	808	31.8	0.0	808	31.8	808	31.8	
(ah) Horizontal	Gear center to the first mounting point	849	33.4	907	35.7	907	35.7	907	35.7	915	36.0	954	37.6	976	38.4	998	39.3	998	39.3	998	39.3
(b)	Distance from the center of the gear to the motor top	1352	53.2	1466	57.7	1466	57.7	1466	57.7	1576	62.0	1513	59.6	1511	59.5	1628	64.1	1628	64.1	1628	64.1
(x)	Tunnel bracket length	496	19.5	496	19.5	496	19.5	496	19.5	496	19.5	496	19.5	496	19.5	496	19.5	496	19.5	496	19.5
Weight assembly (kg/lbs)		330	727	450	992	465	1025	465	1025	575	1267	490	1080	580	1278	740	1631	680	1499	740	1631
Weight motor (kg/lbs)		192	423	305	692	320	705	320	705	440	970	325	717	410	904	570	1257	510	1124	570	1257

MC_0324

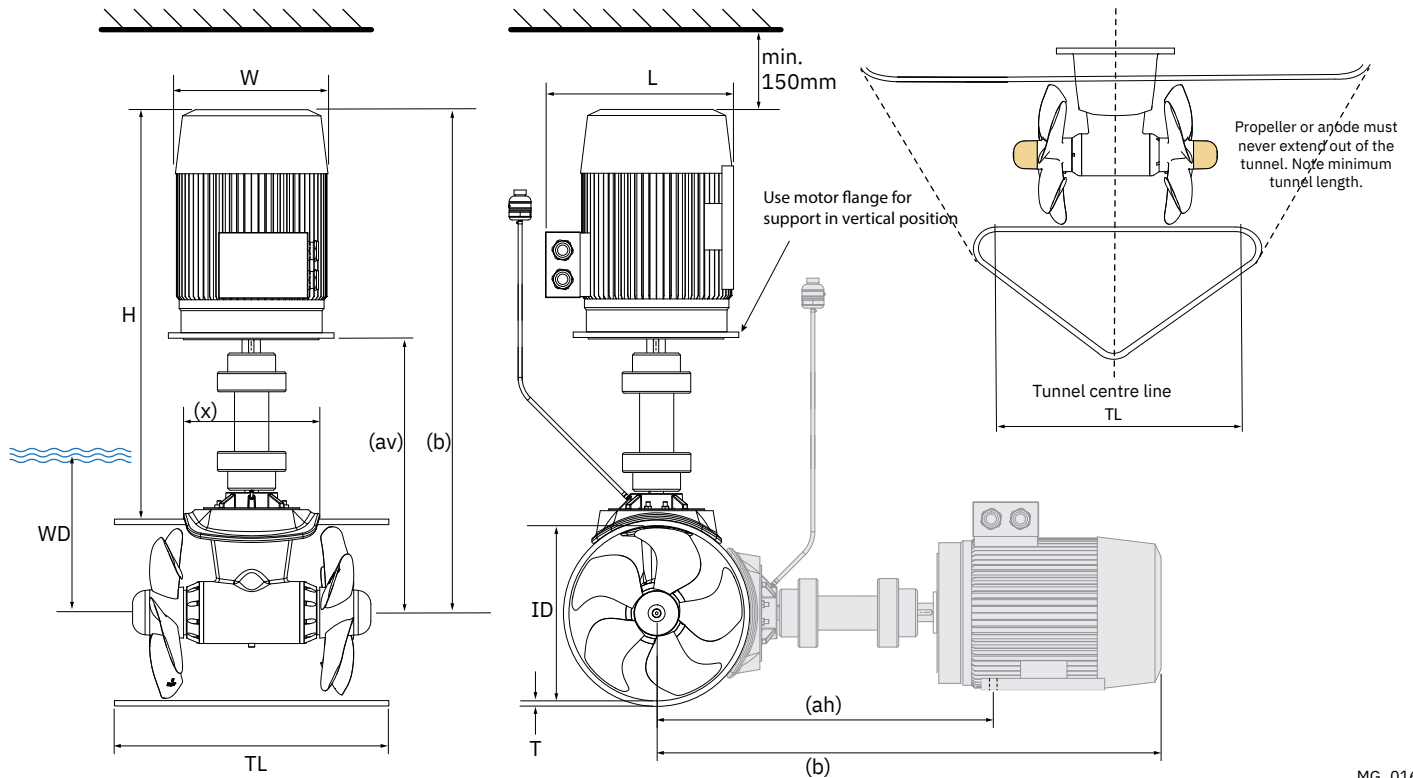

MG_0163

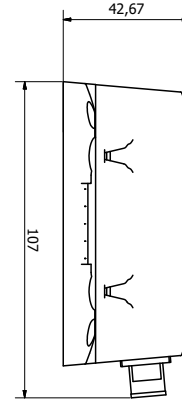
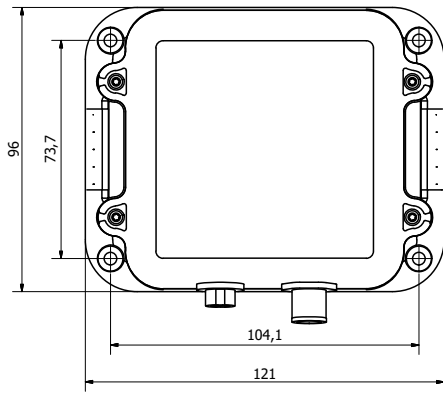

Thruster model	VFD model	Frame size	Voltage range VAC	IP	Weight kg	D mm	W mm	H mm
SAC750/513-I-4-H/V	ACS580-01-088A-4	R5	380-480	21	28.3	295	203	372
SAC750/513-I-4L-H/V	ACS880-31-087A-3	R6	380-415	55	61	383	252	771
SAC900/513-I/C-2HV	ACS580-01-213A-2	R7	200-240	21	54	370	284	880
SAC900/513-I-4-H/V	ACS580-01-106A-4	R5	380-480	21	28.3	295	203	732
SAC900/513-I-4L-H/V	ACS880-31-105A-3	R8	380-415	55	103	496	300	966
SAC900/513-I/C-2-H/V55	ACS880-01-203A-2	R7	208-240	55	54	423	284	880
SAC900/513-C-4-H/V-55	ACS880-01-124A-5	R6	380-500	55	42.9	421	251	726
SAC900/513-C-4L-H/V-55	ACS880-31-105A-3	R8	380-415	55	103	496	300	966
SAC1100/513-I/C-4-H/V55	ACS880-01-274A-2	R8	380-415	55	74	452	300	963
SAC1100/513-I-4-H/V	ACS580-01-145A-4	R6	380-480	21	42.4	369	252	727
SAC1100/513-I-4L-H/V	ACS880-31-145A-3	R8	380-415	55	103	496	300	966
SAC1100/513-C-4-H/V	ACS580-01-145A-4	R6	380-480	21	42.4	369	252	727
SAC1100/513-C-4L-H/V	ACS880-31-145A-3	R8	380-415	55	103	496	300	966
SAC950/610-I-4-H/V	ACS580-01-106A-4	R5	380-480	21	28.3	295	203	732
SAC950/610-I-4L-H	ACS880-31-105A-3	R8	380-415	55	103	496	300	966
SAC1100/610-I-4-H/V	ACS580-01-145A-4	R6	380-480	21	42.4	369	252	727
SAC1100/610-I-4L-H/V	ACS880-31-145A-3	R8	380-415	55	103	496	300	966
SAC1200/610-C-4L-H/V	ACS880-31-145A3	R8	380-415	55	103	496	300	966
SAC1300/610-I-4-H/V	ACS580-01-145A-4	R7	380-480	21	54	370	284	880
SAC1300/610-I-4L-H/V	ACS880-31-145A-3	R8	380-415	55	103	496	300	966
SAC1400/610-I-4-H/V	ACS580-01-169A-4	R7	380-480	21	54	370	284	880
SAC1400/610-I-4L-H/V	ACS880-31-169A-3	R8	380-415	55	124	496	300	966
SAC1400/610-C-4-H/V55	ACS880-01-169A-3	R7	380-415	55	54	423	284	880
SAC1400/610-C-4L-H/V55	ACS880-31-169A-3	R8	380-415	55	124	496	300	966

MC_0708

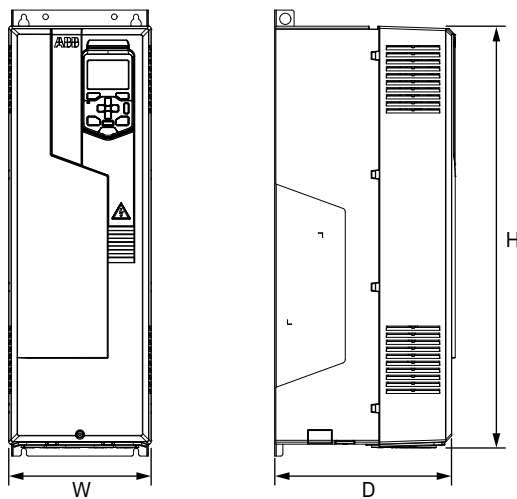
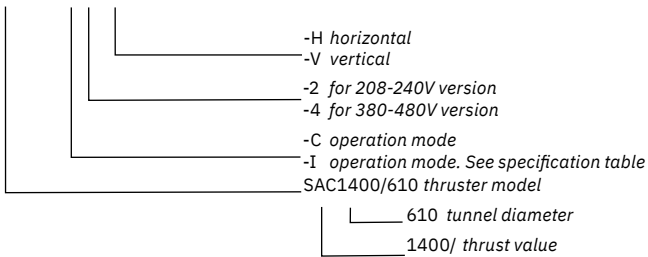

MG_0663

	SAC750/ 513-I	SAC900/ 513-I	SAC900/ 513-C	SAC1100/ 513-I	SAC1100/ 513-C	SAC950/ 610-I	SAC1100/ 610-I	SAC1200/ 610-C	SAC1300/ 610-I	SAC1400/ 610-I/C
Performance & sizing										
Tunnel inside diameter (mm • in)	513 • 20	513 • 20	513 • 20	513 • 20	513 • 20	610 • 24	610 • 24	610 • 24	610 • 24	610 • 24
Thrust, continuous (kg • lbs)	600 • 1323	750 • 1653	900	900 • 1984	1100 • 2425	800•1764	950•2095	1200•2645	1100 • 2425	1200 • 2646
Thrust, max. (kg • lbs) *	750 • 1653	900 • 1984	-	1100 • 2425	-	950 • 2094	1100 • 2425		1300 • 2866	1400 • 3086
Motor output (kW • Hp)**	41 • 56	53 • 72	53 • 72	70 • 95	70 • 95	43 • 58	55 • 74	66 • 89	74 • 101	83 • 113
Typical boat size (m • ft)	29-44 • 95-145	30-45 • 100-150	30-45 • 100-150	32-49 • 105-160	32-49 • 105-160	30-44 • 10-150	32-49 • 105-160	32-49 • 105-160	40-52 • 130-170	40-55 • 130-175
Voltage range, 3-Phase supply	380-440V	380-440V	380-440V	380-440V	380-440V	380-440V	380-440V	380-440V	380-440V	380-440V
Current draw max: ***										
230V Systems:	150A	185A	185A	233A	233A	-	-	225A	-	-
400V Systems:	86A	106A	106A	134A	134A	90A	108A	128A	143A	160A
Generator load max:****	50 KVA	63 KVA	63 KVA	84 KVA	84 KVA	52kVA	66kVA	78kVA	87kVA	97 KVA
Features										
DNV type approved gearleg	Yes (Certificate no. TAM0000DT)	Yes (Certificate no. TAM0000DT)	Yes (Certificate no. TAM0000DT)	Yes (Certificate no. TAM0000DT)	Yes (Certificate no. TAM0000DT)	Yes (Certificate no. TAM0000DT)	Yes (Certificate no. TAM0000DT)	Yes (Certificate no. TAM0000DT)	Yes (Certificate no. TAM0000DT)	Yes (Certificate no. TAM0000DT)
Proportional speed	Yes	Yes	Yes	Yes	Yes	Yes	Yes	Yes	Yes	Yes
Propulsion system	Twin Counter	Twin Counter	Twin Counter	Twin Counter	Twin Counter	Twin Counter	Twin Counter	Twin Counter	Twin Counter	Twin Counter
Lubrication	Gravity feed. On water change (optional)	Gravity feed. On water change (optional)	Gravity feed. On water change (optional)	Gravity feed. On water change (optional)	Gravity feed. On water change (optional)	Gravity feed. On water change (optional)	Gravity feed. On water change (optional)	Gravity feed. On water change (optional)	Gravity feed. On water change (optional)	Gravity feed. On water change (optional)
Galvanic separation (Galvanic separation kit available as option).	No	No	No	No	No	No	No	No	No	No

MC_0836

*) Max thrust is available until the motor winding temperature exceeds 130°C and the dynamic thrust limitation gradually decrease the thrust to continuous rated performance.

***) Motor output @ 230/400V supply. Actual value may vary depending on supply voltage and thruster install.

****) Current draw values are max values set in the VFD parameter setup.

*****) Listed generator load is the maximum load value at standard thruster setup. Note that this value is different from the required generator capacity. Required generator capacity will vary depending on generator characteristics and other loads on the system and have to be selected in cooperation with generator supplier. Side-Power SAC thrusters are in standard version powered by standard Variable Frequency Drives. Low harmonic drives (THD <5%) can be supplied on request. Indicative, recommended generator capacity to be 2 x listed generator load.

1. **Aim to install the thruster as far forward as possible**
 Due to the leverage effect around the boats' pivot point. The distance difference from the boat pivots' point to the thruster will determine the amount of real rotation power for the boat.
2. **Aim to install the thruster as deep as possible.**
 Deeper installations prevent air from being sucked into the tunnel from the surface, resulting in reduced thrust performance and increase noise levels during operation. Deeper installations increase water pressure for maximum efficiency from the thruster.

The tunnel depth is of great importance for optimal thrust. *(Refer to product measurements to define your products recommended depth below the waterline.)* The installer must make evaluations based on thruster performance, boat type and operating conditions. As a general recommendation, the position of the tunnel should not be a minimum of 1/4 of the diameter of the tunnel from the boat keel.

Note: *This can be overlooked depending on the installation methods defined in this manual.*

MC_0003

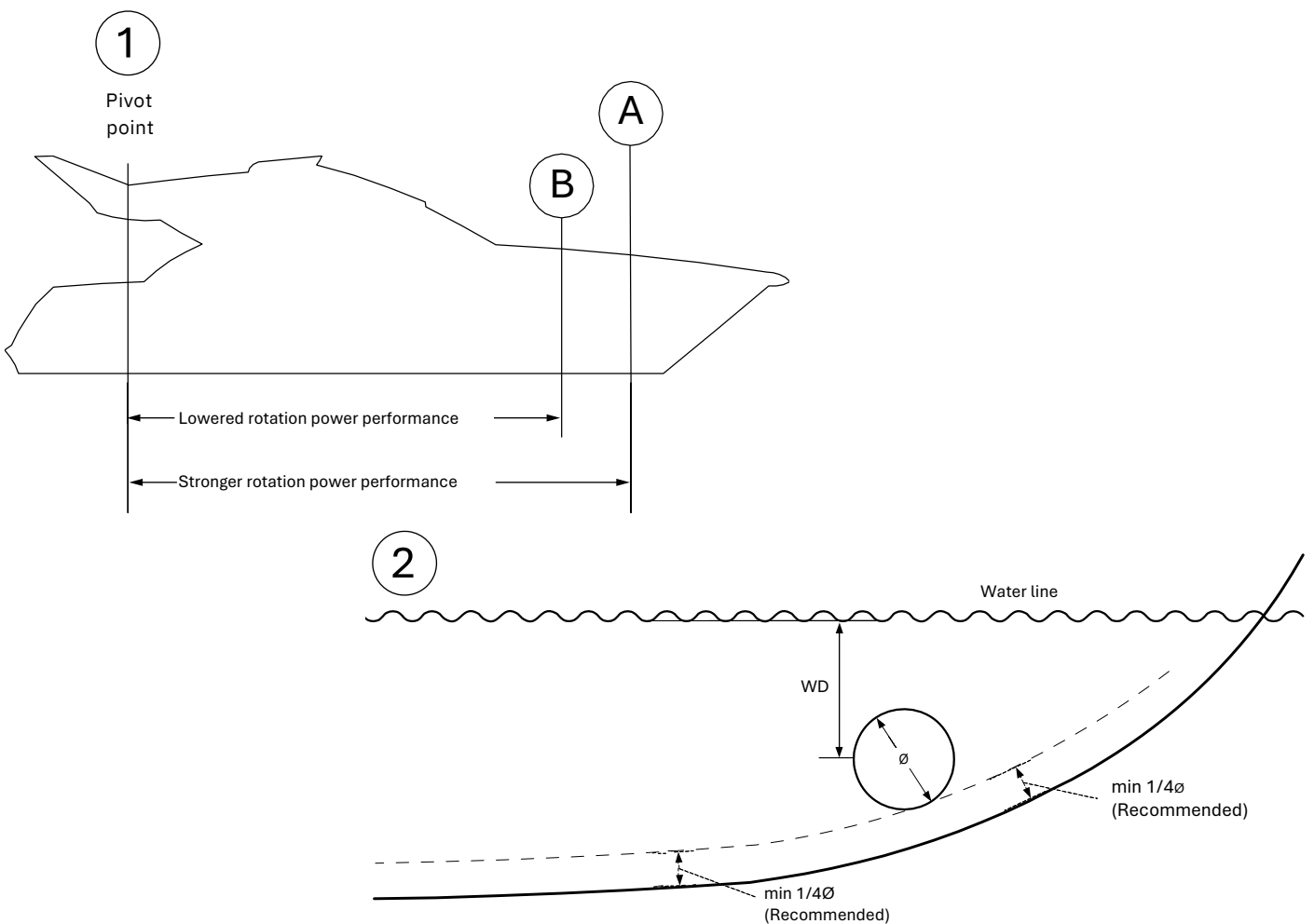

MG 0001

Optimal tunnel length

Achieving the correct tunnel length depends on many factors from the hull type, operation and environmental conditions. Tunnels should avoid being longer than 4 x the tunnel diameter as this will reduce thruster performance.

Note: *Installing long length tunnels can flex/ bend over time and may require additional support. Consult with a naval architect.*

1. Do not allow the variable length of the tunnel walls to vary in length excessively. EG. The top tunnel wall is x 4 longer than the bottom wall.
2. If the tunnel is too long, the friction inside will reduce the water speed and thereby the thrust.
3. If the tunnel is too short (typically only in the bottom section of the tunnel) cavitation problems can occur as water flow will not be able to “straighten” itself before reaching the propeller. This cavitation will reduce performance and increase noise during operation.

Thruster within the tunnel

It is important the propellers and the lower unit/ gearleg must be entirely inside the thruster tunnel. Propellers that protrude from the tunnel will not perform as intended.

4. Standard Use

Tunnel length must be long enough to ensure the propellers are not extruding the tunnel. *(NB: Refer to product measurements to define your products recommended tunnel length.)*

5. Flat Bottom Hull

Tunnel lengths must be longer than the standard measurement outlined within the manual to ensure a circular vacuum is not created between the thruster and the bottom of the boat.

MC_0003

6. High-Speed Boats

Tunnel lengths must be increased to protect the propeller from damage when crashing against the water surface during high-speed cruising. *(NB: This can include the length of a spoiler)*

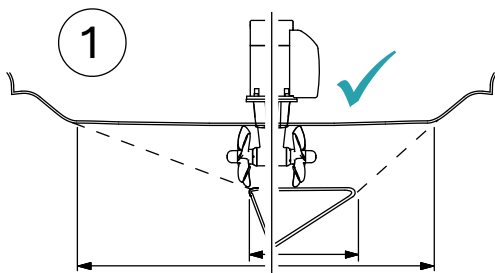

Do not allow the variable length of the tunnel walls to vary in length excessively. EG. the top tunnel wall is x 4 longer than the bottom wall.

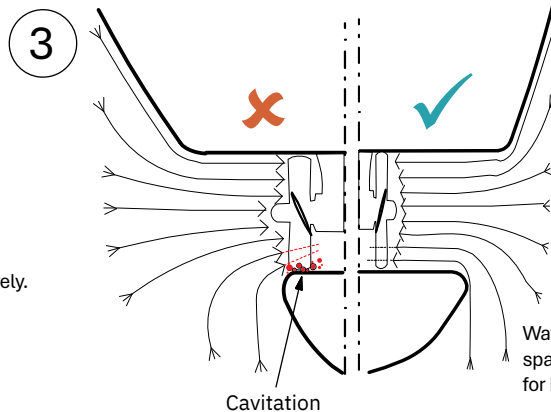

Water flow must have space to "straighten" itself for best performance.

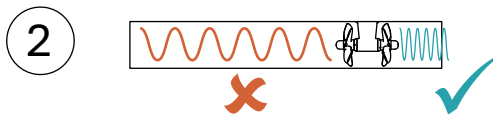

STANDARD USE

FLAT BOTTOM HULL

HIGH-SPEED OPERATION

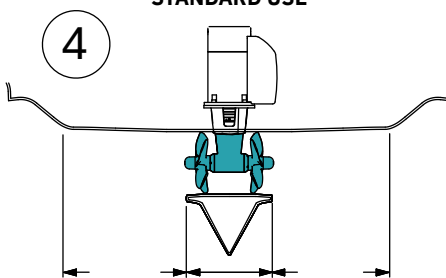

The gearleg/ propeller(s) must never extend out of the tunnel

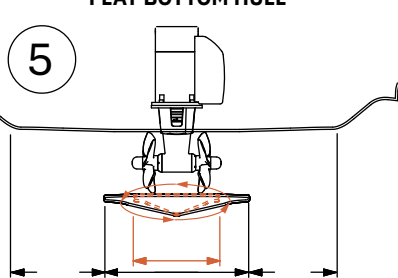

Increase tunnel length to prevent a circular water vacuum cavity between the propeller and the hull of the boat.

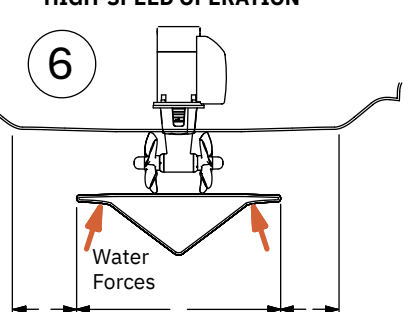

Increase tunnel length to protect the propeller from water forces when high-speed cruising.

MG_0048

Some sail boats have a flat bottom and shallow draft in the bow section. This can make installing the thruster as far forward from the boats main pivot point difficult.

However, it is possible to install a tunnel thruster in most sail boats, even when the hull does not directly support the fitting of a tunnel.

Instead fit the tunnel halfway into the underneath section of the existing hull. Strengthen it with a deflector/ spoiler directing the water flow around the tunnel. This will allow installation of the thruster in the proper position on the boat, maintaining the reliability and space advantages of the tunnel thruster.

This installation is being used by some of the world's largest sail boat builders and has proven to give little to no speed loss during normal cruising. This can also be an installation method for flat bottomed barges to avoid extremely long tunnels and large oval tunnel openings in the hull.

MC_0003

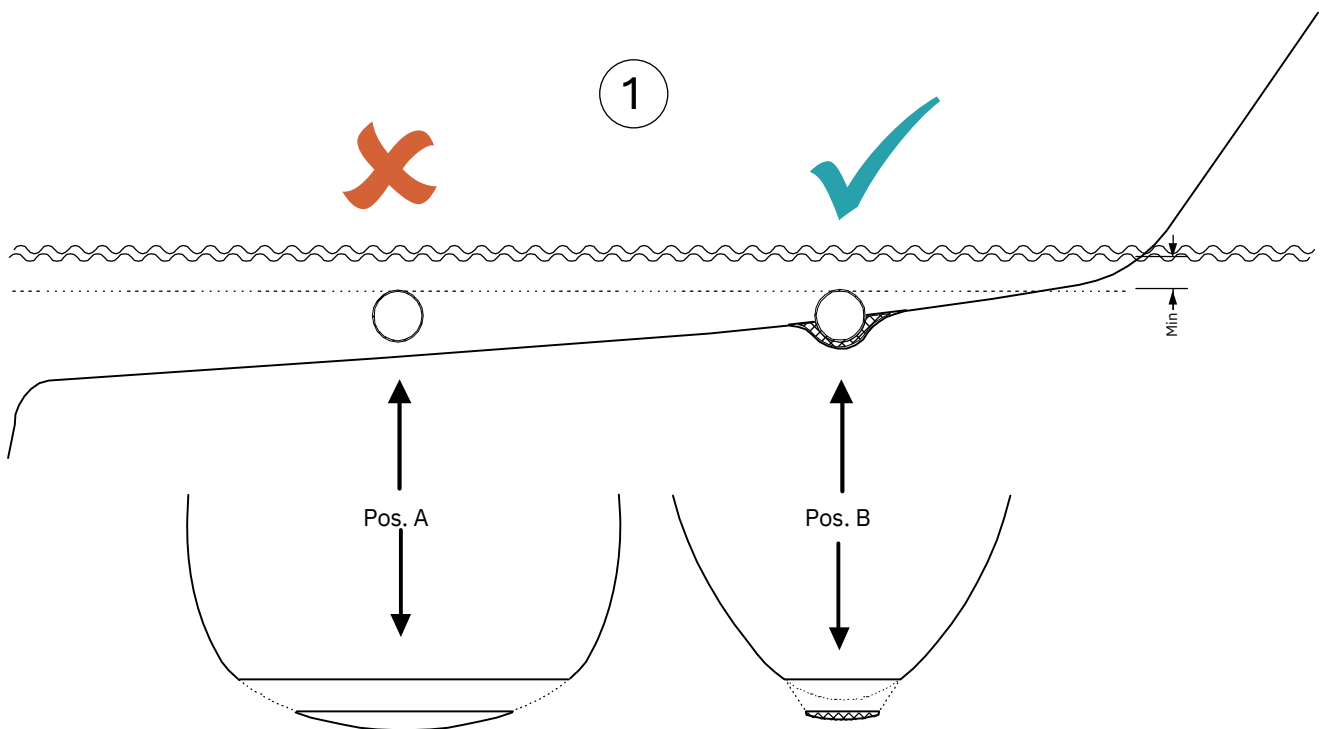

MG_0004

1. A possible problem in sail boats or fast powerboats is that a non-rounded surface can generate drag from the back face of the tunnel, as it creates a “flat” area facing the flow of water.

This problem can be solved in two different ways, depending on what is possible or easier to perform.

2. The best solution which generally reduces the most drag is to make a recess in the hull at the back of the tunnel. As the back face is removed water can flow freely past the tunnel entry. The depth and shape of this recess will depend on the boat and the angle facing up/ down aft of the tunnel insert. Normally it is angled slightly down because of the water flow on this area.
3. Making a deflector/ spoiler in front and underneath the tunnel can also reduce damage to the thruster and drag. The deflector/ spoiler will push the water flow out from the hull so water can pass by the back face of the tunnel. The shape and size of this deflector/ spoiler will depend on the hull shape. The easiest way of making the deflector/ spoiler is to retain a part of the lower forward area of the tunnel while installing the tube. Use this area as support to mould a soft curve/spoiler shape from the hull.
4. The thruster propeller can spin (passively) producing noise while sailing or cruising as water is forced through the tunnel. Water-flow directed through the tunnel at high speeds, during turning or as the boat bumps waves while underway can also damage the thruster.

Note: As a rule, you should not see the back face of the tunnel when standing directly in front of the boat looking aft.

MC_0003

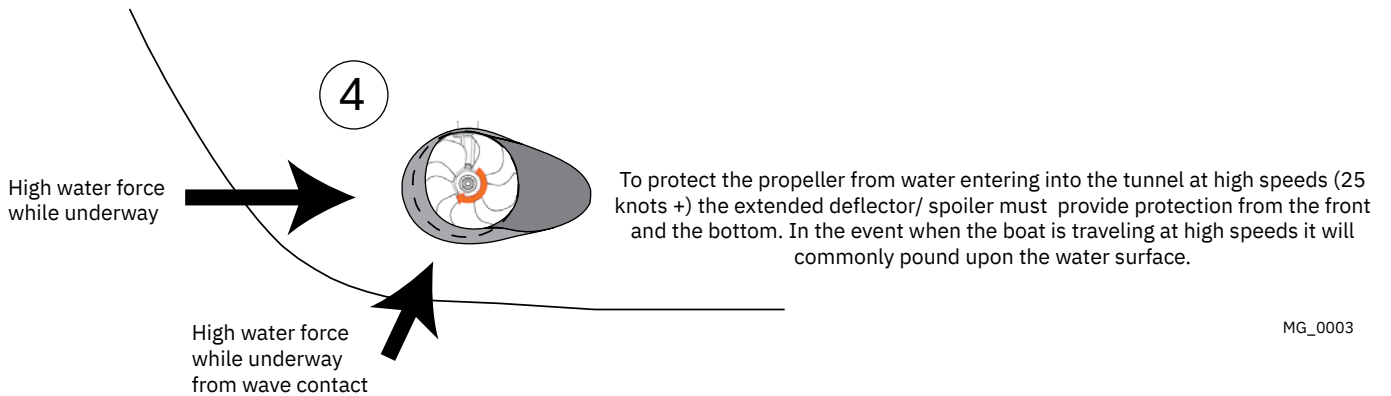
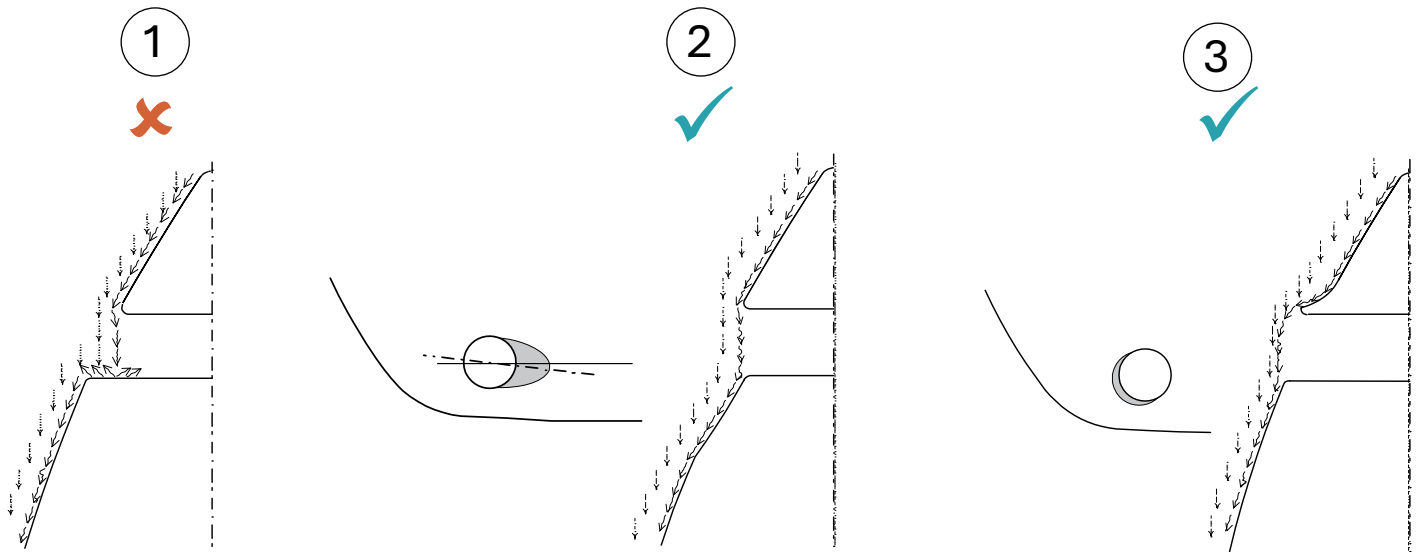

MG_0003

Rounded tunnel ends will maximise thrust and minimise noise and cavitation.

For best performance round the tunnel connection to the hull-side as much as possible. The minimum rounding has a radius of 10% of the diameter of the tunnel.

Significant advantages of a rounded tunnel over a sharp tunnel to hull connections are:

1. A rounded tunnel end will prevent the creation of turbulence/ cavitation created from a sharp tunnel end when water passes by the tunnel.
 - The turbulence/ cavitation will block the outer area of the tunnel and thereby reduces the effective tunnel diameter and thrust.
 - Turbulence/ cavitation on the propeller will lessen the thrusters performance and create excess noise.
2. For steel/ aluminium hulls angled tunnel ends also offer similar performance as a rounded connection.
3. A rounded tunnel end makes the thruster draw water from along the hull-side, creating a vacuum that will suck the boat sideways and thereby give additional thrust.
 - With a sharp tunnel end, the thruster will be unable to take water from along the hull-side, and you will not gain the desired vacuum and additional thrust. This “free” extra thrust in optimal installations be 30 - 40% of the total thrust.

Note: A Sleipner thruster propeller does not produce cavitation at working speed. Therefore, any cavitation and cavitation noise in the tunnel will be caused during improper tunnel installation.

MC_0003

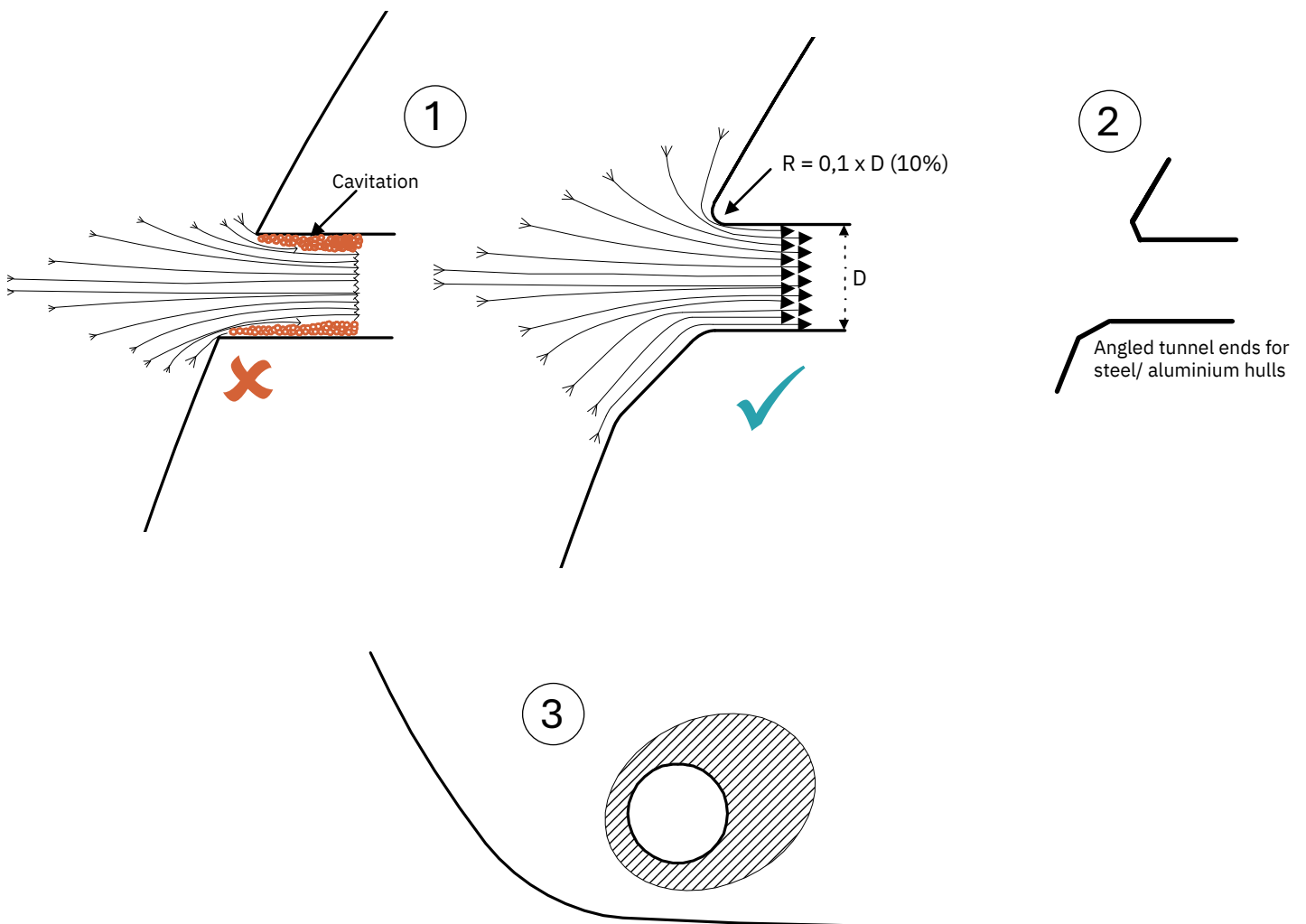

MG_0002

The following are only general instructions and do not explain in any way the details of fibreglass work. Problems caused by faulty installation of the tunnel, are the installers full responsibility. It is recommended to consult a naval architect before modifying the hull.

1. Find the position in the boat considering the information earlier in this manual and the applicable measurements for the thruster model you are installing. Mark the centre of the tunnel on both sides of the hull. Drill a hole horizontally at these marks.
2. Mark the circle for the tunnel opening (outside diameter of the tunnel) and cut the hole. (Special tool available. Contact your dealer or distributor).
3. Grind off the gel coat to the “real fibreglass” in a sufficient area around the hole, on both inside and outside of the hull, to ensure a secure attachment when bonding the tunnel to the hull.
4. Insert the tunnel and mark its shape to fit the hull.
Note: if you are installing with a deflector/ spoiler, leave a part of the tunnel in the front and underside of the tunnel that will cover the back face.
5. Cut the tunnel ends to the desired shape and lightly sand its surface. Clean the area with acetone or similar where you are going to apply fibreglass.
Note: Do not cast or add fibreglass to the area were the thruster will be placed.
6. Cast the tunnel to the inside of the hull, with sufficient layers of fibreglass, type of fibreglass and resin, preferably alternating mat and roving types of fibreglass. To round the tunnel ends to a 10% radius make further layers inside to preserve the desired hull thickness.

Note: These guidelines are for reference only. Consult a naval architect to ensure proper installation.

Note: Ensure gaps between the tunnel and the hull are completely filled with resin/ fibreglass. In areas where you can not access to make layers of resin/ fibreglass, a resin/ fibreglass mixture must be used in that area.

MC_0003

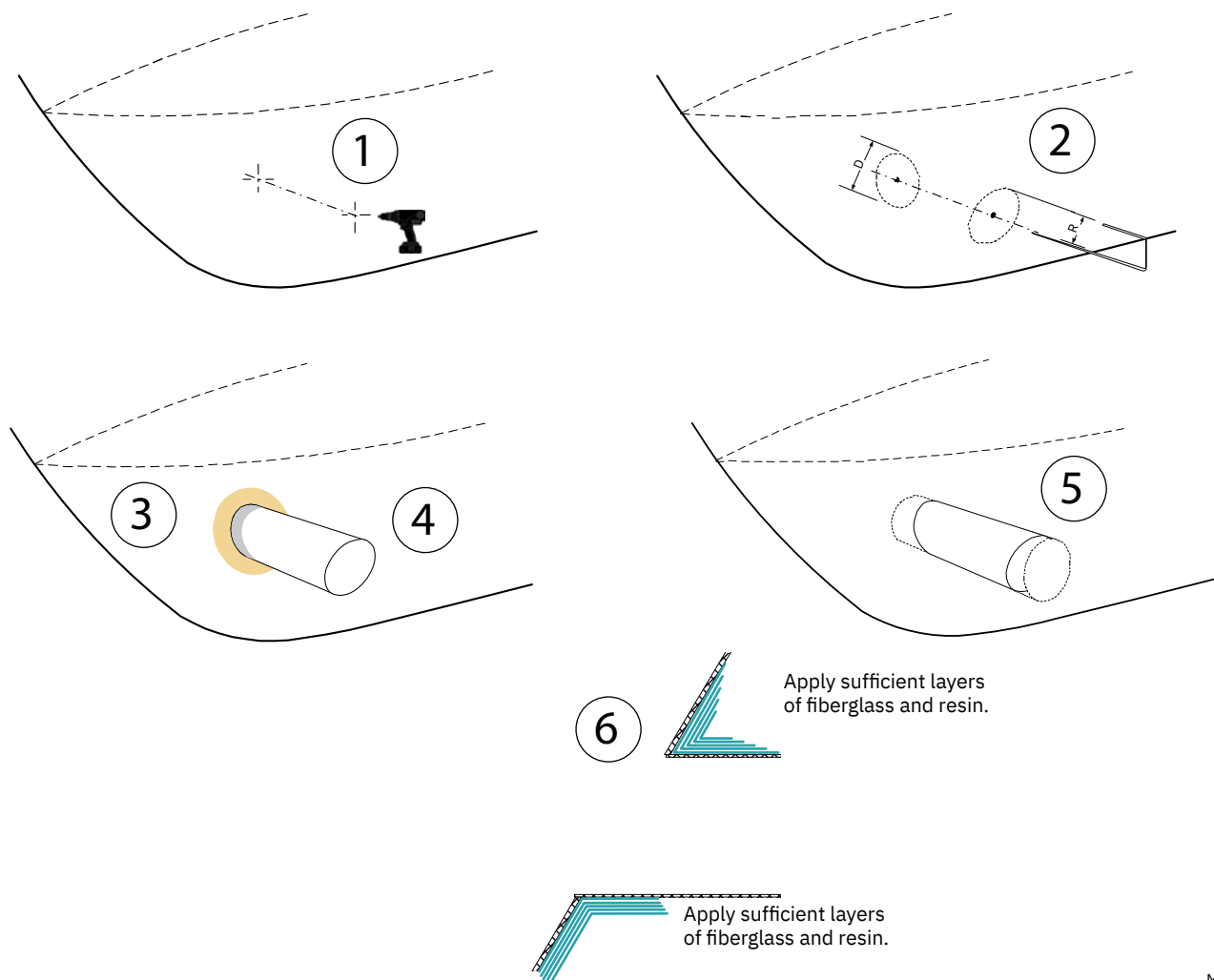

MG_0005

With tunnel installed and cast.

1. Round the edges with a radius of 10% of the tunnel diameter.
2. For steel/ aluminium hulls make a slope with a length of 10-15% of the tunnel diameter.
Note: If this is not possible, round the tunnel end as much as possible.
3. Additionally laminate an adequate number of layers on the outside of the tunnel and hull, covering a sufficient area. Use lamination materials which is compatible with the hull and tunnel materials.
The tunnel material is GRP, Glassfiber Reinforced Polyester.
4. Follow the same method if making the deflector/ spoiler.

You must apply waterproof coating to the areas that is grinded and moulded to make the surface waterproof. If not, these areas will allow water to penetrate the hull, which is typically not waterproof without these applications outside.

Note: All original Sleipner tunnels are fully waterproof when delivered except in the areas where you have cut and bonded it to the hull.

Avoid all modification of the tunnel where the motor-bracket is to be placed, as this will cause misfit and possible failure to the gearleg.

MC_0003

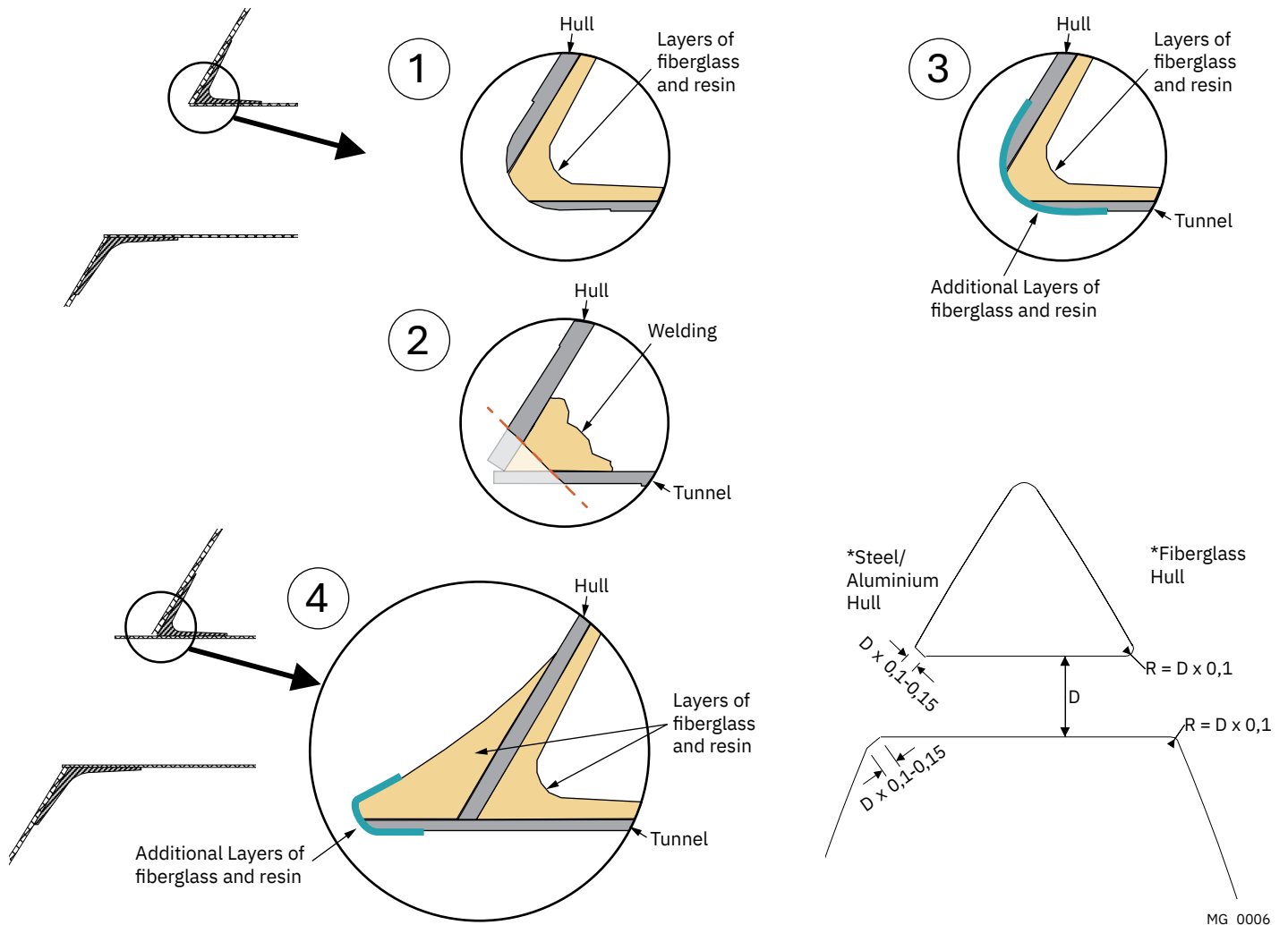

For Stern Thruster installation please refer to the supplied manual in your Sleipner product delivery

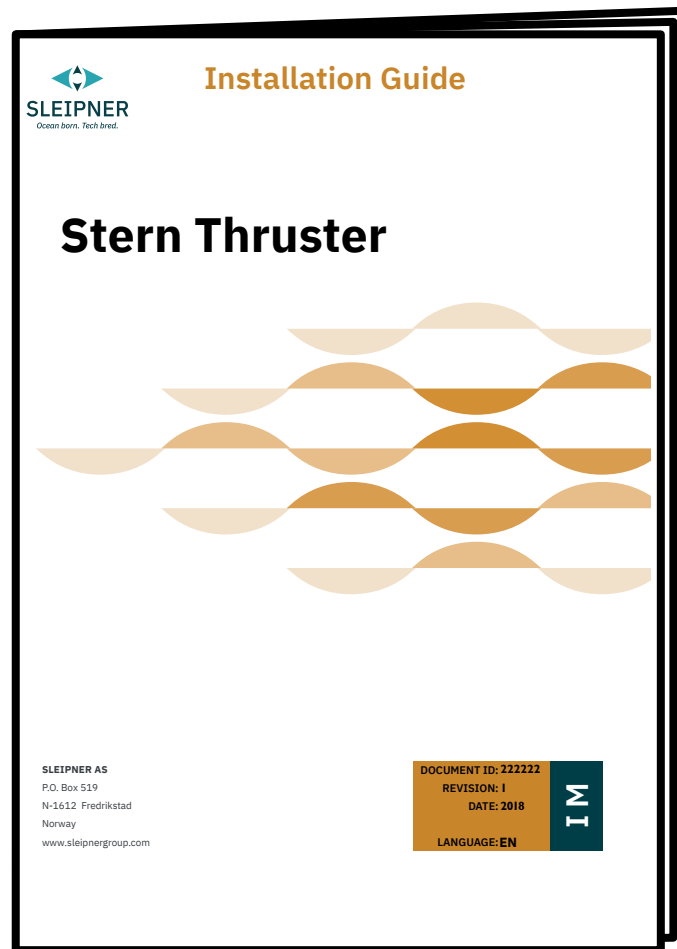

MC_0003

For supporting stern tunnel installation documentation, we advise you to visit our website www.sleipnergroun.com and find your Sleipner stern tunnel model.

Important installation notice:

- Do not mount the thruster directly to the metal hull without galvanic isolation. Contact your dealer for purchasing the correct isolation kit, incl. installation instructions.
- Use only approved Sleipner isolation components.
- Follow the installation instructions included with the isolation kit.

1. Mark the tunnel centreline and the boat's centreline.
2. Use the gasket or template (recommended) to mark the hole centres and double-check the measurements. The centre hole MUST be placed using the boat centreline as shown above. **(NB: All holes must be in-line with the tunnels' centreline for correct installation, clearance between the propeller and the tunnel is minimal.)**
3. Drill the main centre hole followed by the bolt holes. See dimensions in the table below.
4. Smooth the area where the thruster components will be in contact with the tunnel.

MC_1097

Thruster model	Measurements									
	ØA		B		ØC		D		ØE (Optional, for on-water oil change)	
	mm	inch	mm	inch	mm	inch	mm	inch	mm	inch
SACxxx/513 SACxxx/610	116	4.5	95	3.7	17	0.7	25	1	17	0.7

MCT_0006

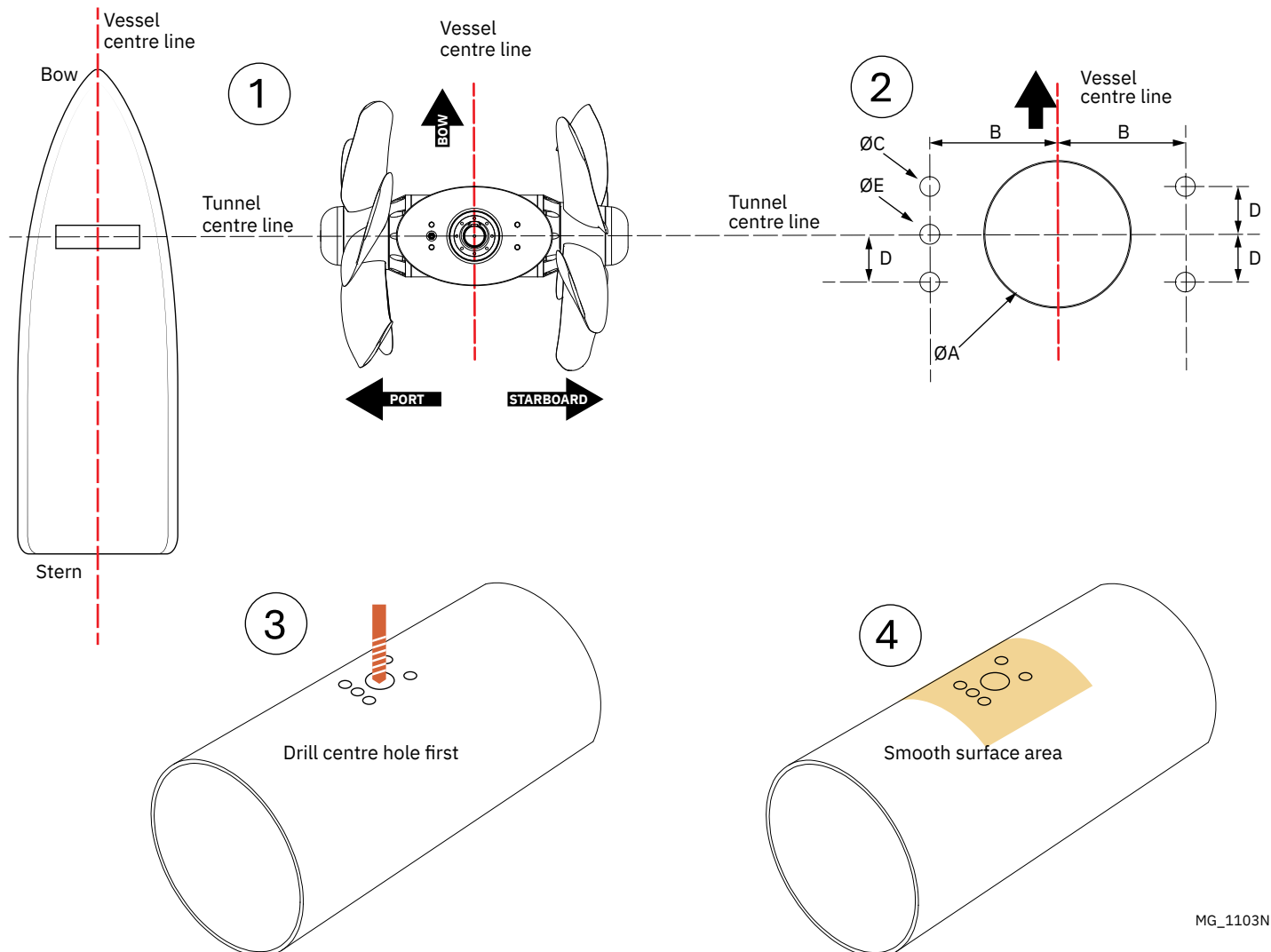

MG_1103N

5. Fill the gearleg with oil from the lowest drain point until it oozing out from the top of the gearleg. Enter and tighten the oil drain plug when filling is complete.
Use oil type API GL-5, SAE 80W-90
 6. Enter the gearleg with the gasket mounted, in to the tunnel.
Note that there are threaded holes in both the propeller and the motor shafts, where the purpose is to enter an eye bolt for supporting the push and lift movement of the gearleg.
 7. When the gearleg is in alignment with the predrilled holes in the tunnel, lift the gearleg to enter these holes. Keep the gearleg in position by supporting it underneath with a wood block or similar.
 8. Apply oil or grease on the O-rings in the motor bracket before mounting it together with the gear house, to prevent damaging the O-rings during insertion. **(NB: The gearleg neck and the inner surface of the motor bracket must remain clean.)**
 9. Lower the gasket and bracket to the gearleg. Enter the nuts, and tighten slightly.
 10. Place the propeller on the propeller shaft and ensure that it is free rotating without touching the tunnel walls, and has the same clearance from each blade to the tunnel wall. Also verify that the gearleg shaft has the correct height in relation to the bracket.
- Disassemble the gearleg and the bracket from the tunnel.

MC_1098

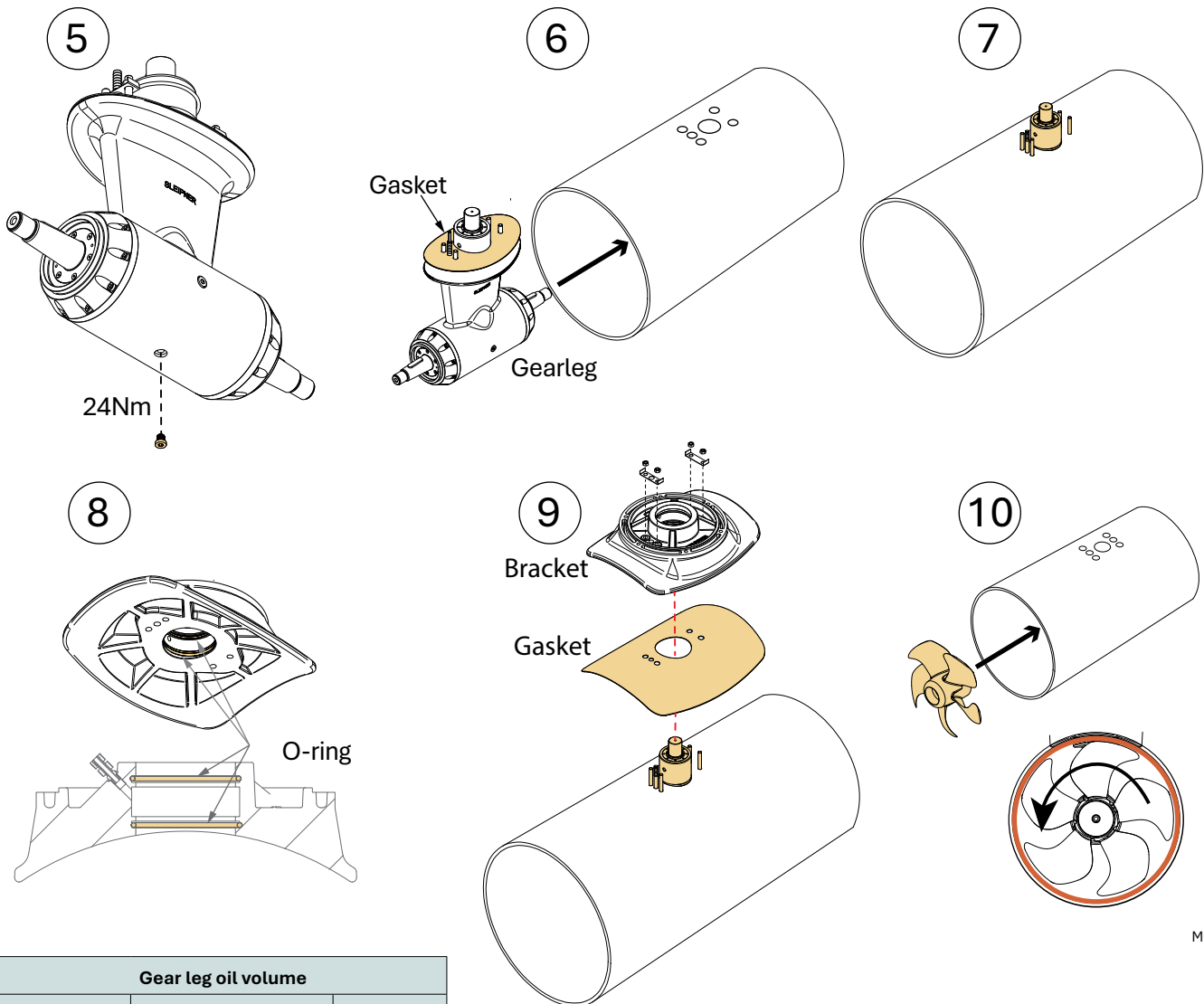

MG_1104

Gear leg oil volume		
Models	Oil type	Oil volume
SACxxxx/513	API GL-5, SAE 80W-90	3,3L
SACxxxx/610	API GL-5, SAE 80W-90	3,7L

MC_0917

11. Apply an appropriate sealant to both sides of the gearleg gasket, and place the gasket on the gearleg. (See your sealant data sheet for the correct application process.)
12. Enter the gearleg with the gasket mounted, in the tunnel. **Note that there are threaded holes in both the propeller and the motor shafts, where the purpose is to enter an eye bolt for supporting the push and lift movement of the gearleg.**
13. When the gearleg is in alignment with the predrilled holes in the tunnel, lift the gearleg to enter these holes. Keep the gearleg in position by supporting it underneath with a wood block or similar.
14. Apply an appropriate sealant to both sides of the tunnel gasket, and place the gasket on the tunnel, aligned with the gearleg boss and bolts.
15. Lower the bracket to the tunnel, aligned with the gearleg boss and bolts.
16. Fasten the gearleg and the motor bracket with the bolts provided. Tighten to torque as shown.

Note: Apply thread paste to the threads when entering to prevent the nut and bolt from seizing and get stuck.

MC_1104

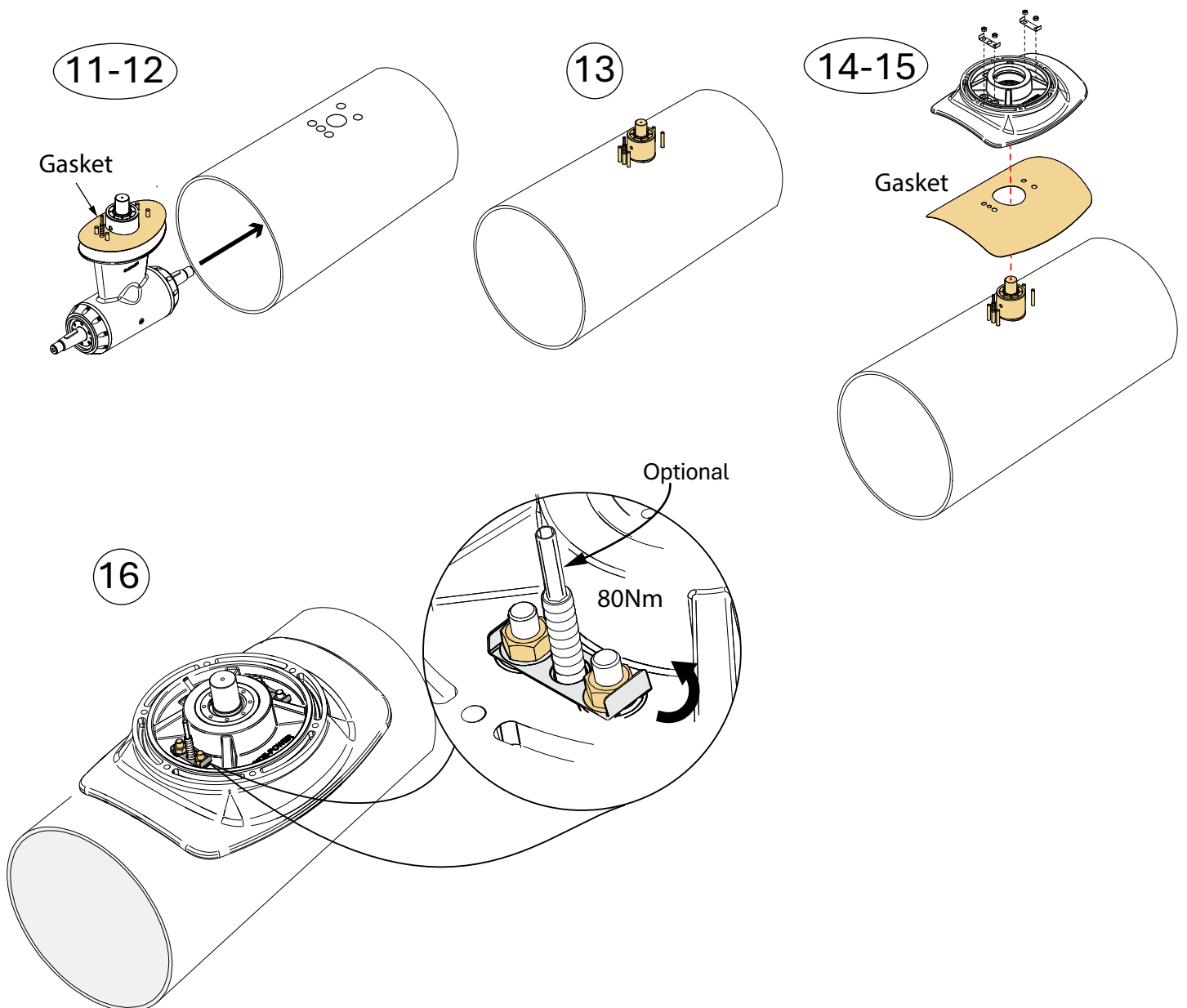

MG_1105

NOTE: Only install one of the propellers at this stage. The second propeller must be installed after the oil filling procedure.

1. Rotate the propeller shaft so the shaft key way is facing up. Remove the tape holding the parallel key in place on the propeller shaft.
2. Insert the propeller onto the propeller shaft until the propeller key aligns into the slot/ groove in the propeller. **(NB: Installation requires almost no gap (approximately 1mm) between the propeller and the gearleg.)**
3. Apply waterproof grease only to the thread where the bolt will be fastened to achieve required torque tension. **Do NOT apply grease to the internal propeller core.**
4. Without the washer, fasten the propeller lock-nut to the required torque.
5. Remove the propeller lock-nut from the shaft.
6. Grease the washer surface facing the propeller lock-nut.
7. Insert the washer on the propeller shaft and re-fasten the propeller lock-nut to required torque tension. **(NB: Ensure the washer tab is inserted into the slot/ groove in the propeller. Fold the tab washer over the nut after fastening).**
8. Attach the anode hub to the propeller shaft, and enter and tighten the bolt(s) holding the anode.

MC_1001

Install propellers with the (LH) left-hand marking on the (P) port side shaft and (RH) right-hand markings on the (S) starboard side shaft for twin counter-rotating gear leg systems.

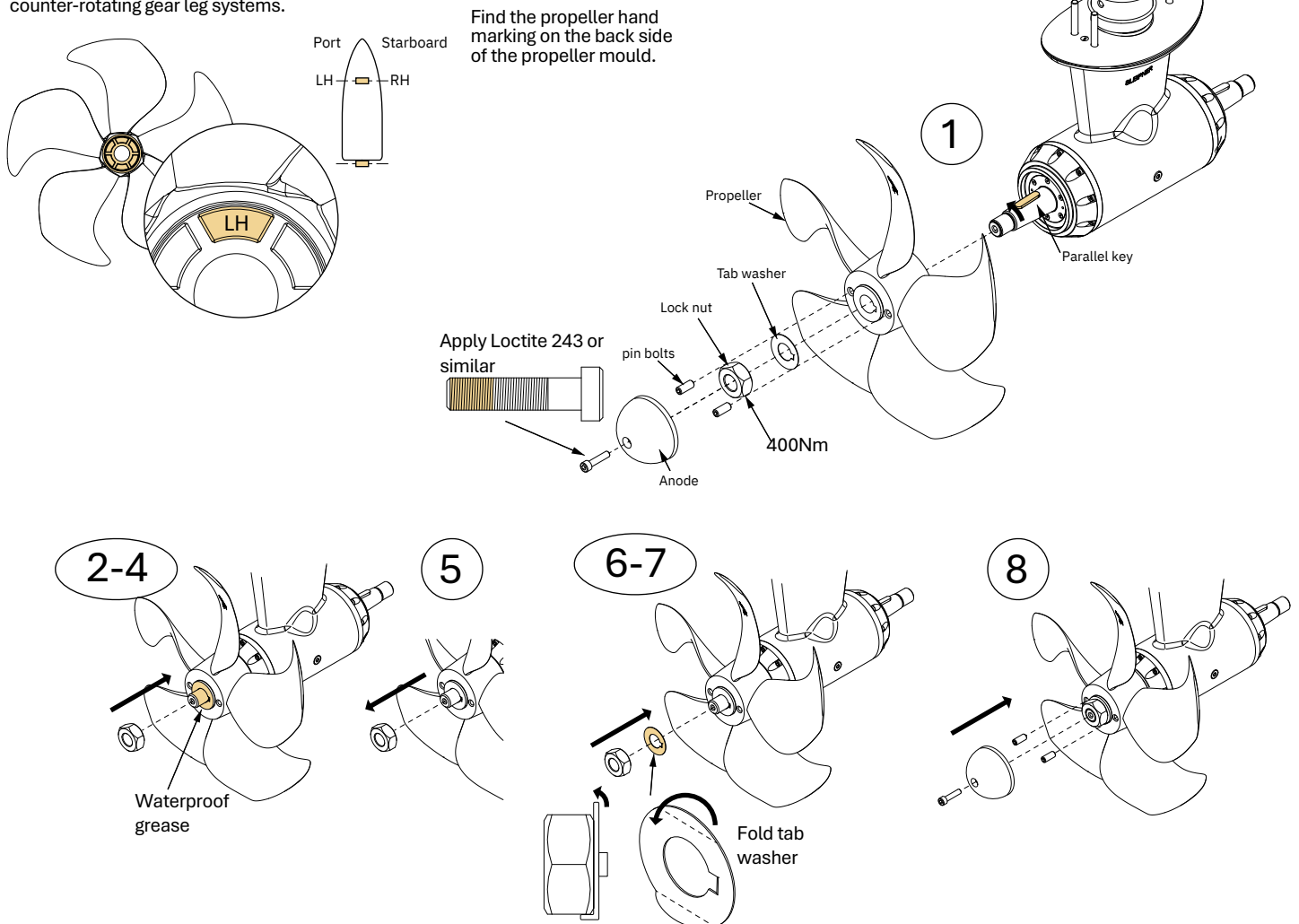

Consult a naval architect regarding these issues.

MC_1110

- Verify if added support is required between the tunnel and the hull. **(Reference 1 & 2).**
- The motor must be mounted on a separate bedding. **(Reference 3).** The bedding must be rigid and dimensioned to support the weight and torque specified in the technical data of the product.
- The bedding must be in the correct height and angle. The angle of the cardan shaft must not exceed +/- 1.5 degrees **(Reference 4).**
- Reference the distance from the centreline of the tunnel to the top of the bedding for the specific thruster/ motor combination. Ensure that the bedding is parallel to the centreline by checking the distance in both ends of the bedding.
- Mounting holes in the bedding should be drilled according to measurements for the specific thruster/ motor model.

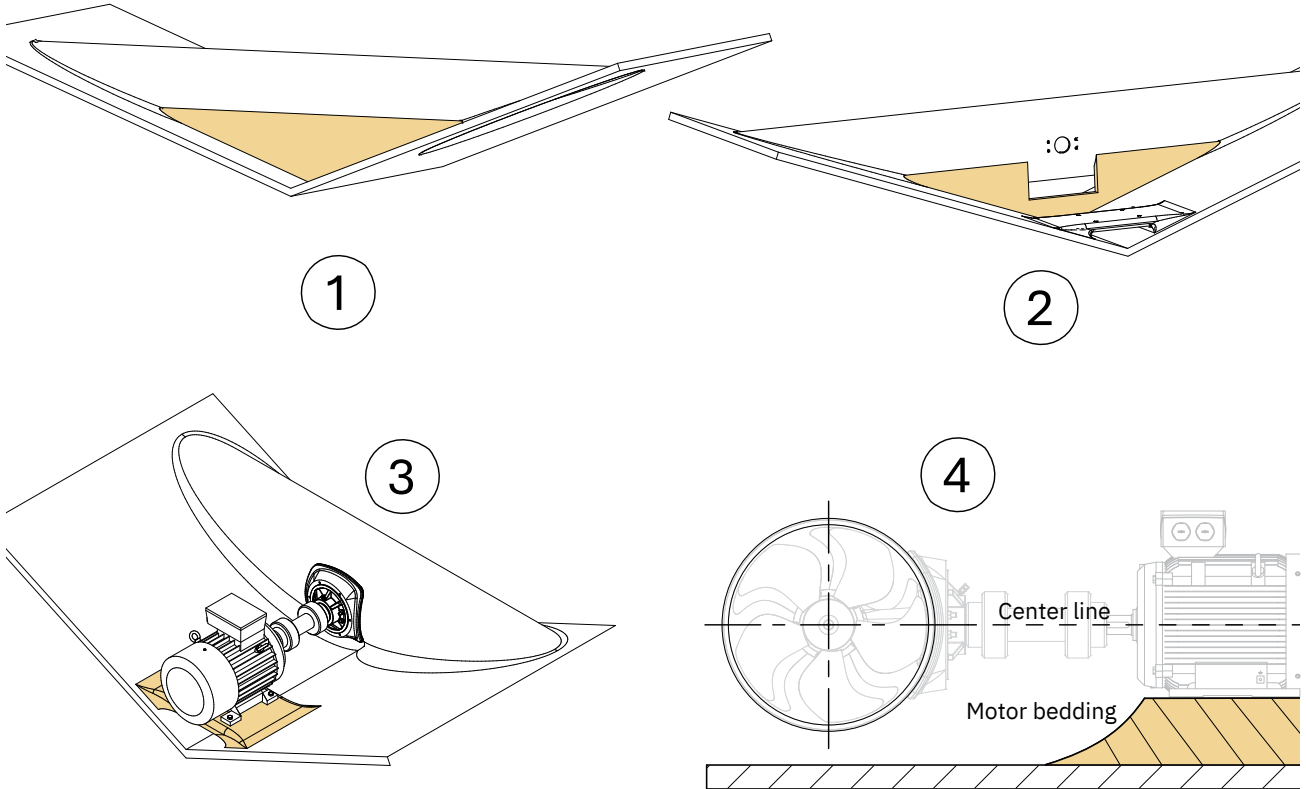

Motor support, Vertical installation

Consult a naval architect regarding these issues.

Use the motor flange as support for vertical installations. **(Reference 5).**

A bracket must be manufactured for fastening the motor. This bracket must be designed so that the specified installation dimensions for the relevant motor are maintained, and also be adapted to the actual hull structure. Consult a naval architect for this purpose.

MC_1111

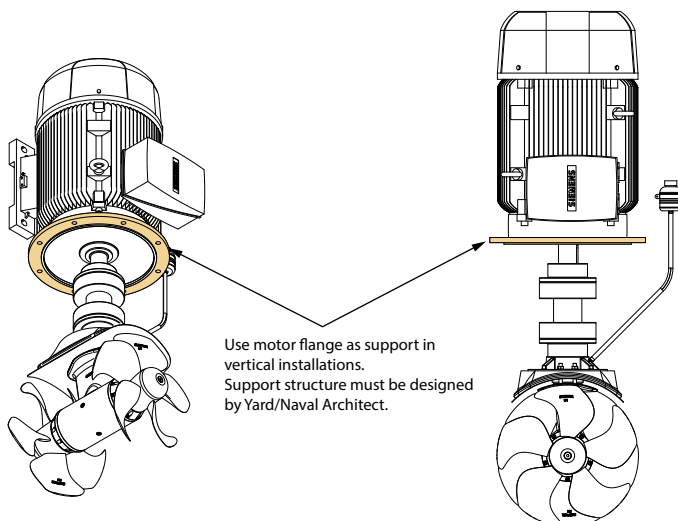

MG_0712_01

	Weight kg	Ø1	Ø2	Ø3	Ø4	Ø5	H	H1	H2	L1	L2	A	A1	B	C1	C2	D	L3	L4
SAC750/513	192	4 x 18,5	300	350	400	55	496	296	5	110	636	305	x	318	18,5	25	200	746	243
SAC900/513-I	305	8 x 18,5	350	400	450	60	563	338	5	140	708	286	25	356	19	25	225	848	289
SAC900/513-C	320	8 x 18,5	350	400	450	60	563	338	5	140	708	286	25	356	19	25	225	848	289
SAC1100/513-I	320	8 x 18,5	350	400	450	60	563	338	5	140	708	286	25	356	19	25	225	848	289
SAC1100/513-C	440	8 x 18,5	450	500	550	65	660	410	5	140	817	349	x	406	24	30	250	957	308
SAC950/610	325	8 x 18,5	350	400	450	60	563	338	5	140	708	286	25	356	19	25	225	848	289
SAC1100/610	410	8 x 18,5	450	500	550	65	660	410	5	140	817	349	x	406	24	30	250	957	308
SAC1200/610	570	8 x 18,5	450	500	550	75	713	433	5	140	820	368	51	457	24	30	280	960	330
SAC1300/610	510	8 x 18,5	450	500	550	75	713	433	5	140	820	368	51	457	24	30	280	960	330
SAC1400/610	570	8 x 18,5	450	500	550	75	713	433	5	140	820	368	51	457	24	30	280	960	330

MC_0979

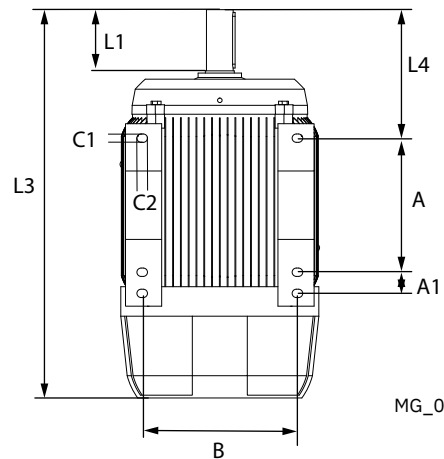
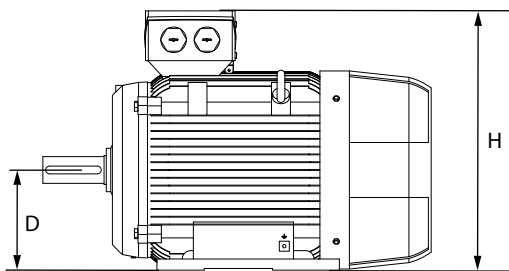
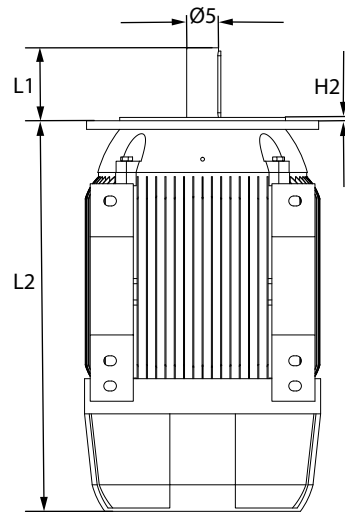
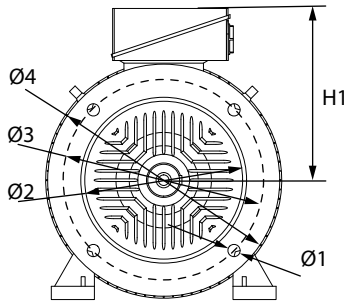

MG_0981

Parts must be aligned with precision to ensure the longevity and effectiveness of the coupling, consider the combination of axial, radial and angular misalignment.

NOTE:
Only use original bolts delivered with the Sleipner thruster. Also, avoid contact between the AC motor shaft and the coupling drive shaft.

Centa has applied retention Inbus Plus all glue to all bolts. **(NB: The glue will harden within 4-5 hours at 20° C.)** Additional use of any loctite or anaerobic adhesives will destroy the natural vulcanisation of the rubber. Do not use oil or grease on bolts except a small amount of grease at the contact areas between bolt heads and rubber element bushings. Grease will avoid the twisting of the rubber element during bolt fastening.

1. Insert the flange hub on AC motor shaft and gearleg shaft. **(NB: Insert the Gear leg shaft flange hub against the limit stop/ shaft shoulder.) Insert the AC motor shaft flange hub according to hub depth.)**

NOTE: The fit between the shaft and the flange is tight, and the flange must be heated in order to fit onto the shaft.

2. Install and line up the AC motor according to tolerances given in the provided table.
3. Insert the drive shaft inside the rubber elements. Insert radial bolts into radial sections of the rubber elements, and fasten 2-3 threads only into the drive shaft.

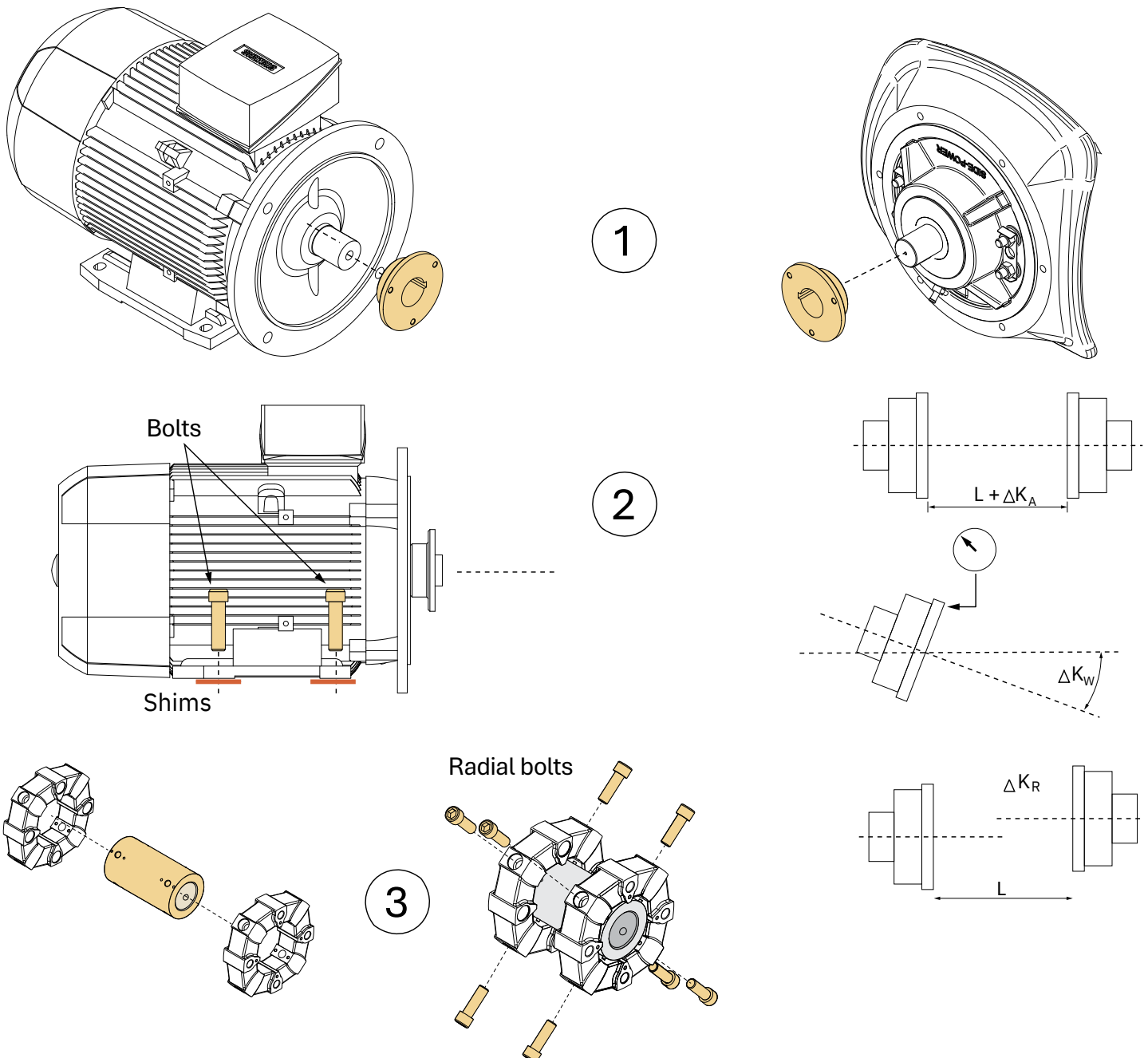

4. Install the pre-mounted rubber elements and shaft between the two flange hubs. Insert the Axial bolts and fasten 2-3 threads only into the flange hubs.
5. First fasten radial bolts, then the axial bolts according to the table above. *(NB: Ensure rubber elements are not twisted during fastening the bolts.)*

NOTE:
Fastening bolts by hand/ user judgment is not sufficient as this will result in a final bolt torque too low for operation. A low bolt torque will allow the bolts to loosen over time, destroying the shaft. A torque wrench must be used to fasten bolts to specified torque tension.

Maintenance and Safety Precaution:

The coupling is entirely maintenance free. Avoid contact with oil and similar substances since the natural rubber is not oil resistant. For a detailed Universal Joint Shaft installation manual, contact your Slepner dealer. Add protection to the Universal Joint Shaft according to relevant safety regulations. *(NB: A protection guard is not a part of Slepner delivery.)*

MC_0027

Model	Coupling size	Axial and radial bolts		L *)	Axial tolerances Complete shaft ΔKa (mm)	Angular misalignment Each joint	Radial tolerance
		Dim.	Torque	mm		ΔKw	ΔKR
SAC750/513	25	M14x40	140 Nm	200	+/- 1	0.15°	0.5mm
SAC900/513	25	M14x40	140 Nm	200	+/- 1	0.15°	0.5mm
SAC1100/513	30	M16x50	220 Nm	200	+/- 1	0.15°	0.5mm
SAC950/610	30	M16x50	220 Nm	200	+/- 1	0.15°	0.5mm
SAC1100/610	30	M16x50	220 Nm	200	+/- 1	0.15°	0.5mm
SAC1200/610	50	M16x50	220 Nm	200	+/- 1	0.15°	0.5mm
SAC1300/610	50	M16x50	220 Nm	200	+/- 1	0.15°	0.5mm
SAC1400/610	50	M16x50	220 Nm	200	+/- 1	0.15°	0.5mm

MCT_0006

Note! All installation tolerances require a rigid AC motor installation.

*) To be checked prior to installation. Lengths can vary depending on customer requirements.

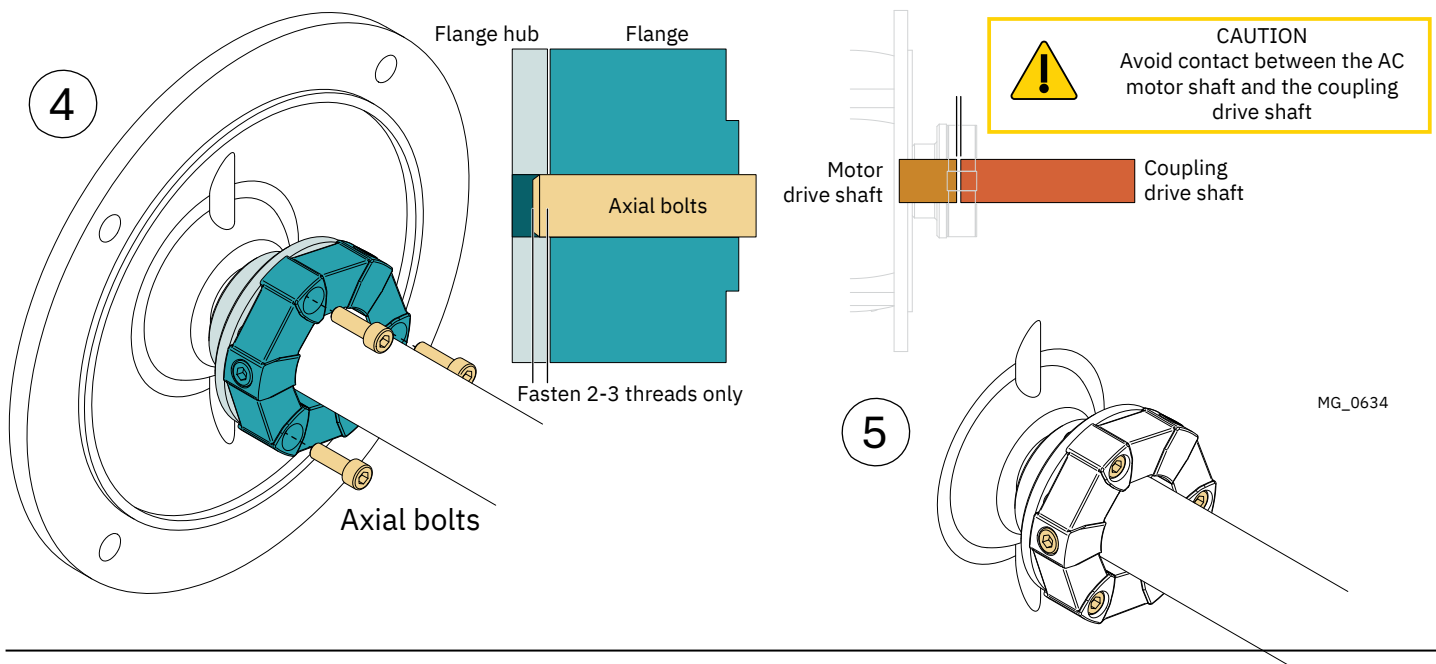

MG_0634

1. Install the oil container above the waterline by at least 20% of the distance from the waterline to the centre of the tunnel. This ensures enough overpressure for the oil in the gearleg.
2. Install the oil tube from the oil container to the feed nipple on the motor bracket. Fasten both the tube clamp screws. **(NB: Ensure the oil tube has no loops and forms an airlock to stop the oil flow. Ensure the oil tube angle is sufficient to allow oil to flow freely into the gearleg.)**
3. Fill the oil container with the same gear oil used in the gearleg. The oil container works as an indicator to ensure oil is in the gearleg at all times.

(NB: Fill and drain the gearleg simultaneously while replacing the oil to ensure the system is never empty.) . MC_0023

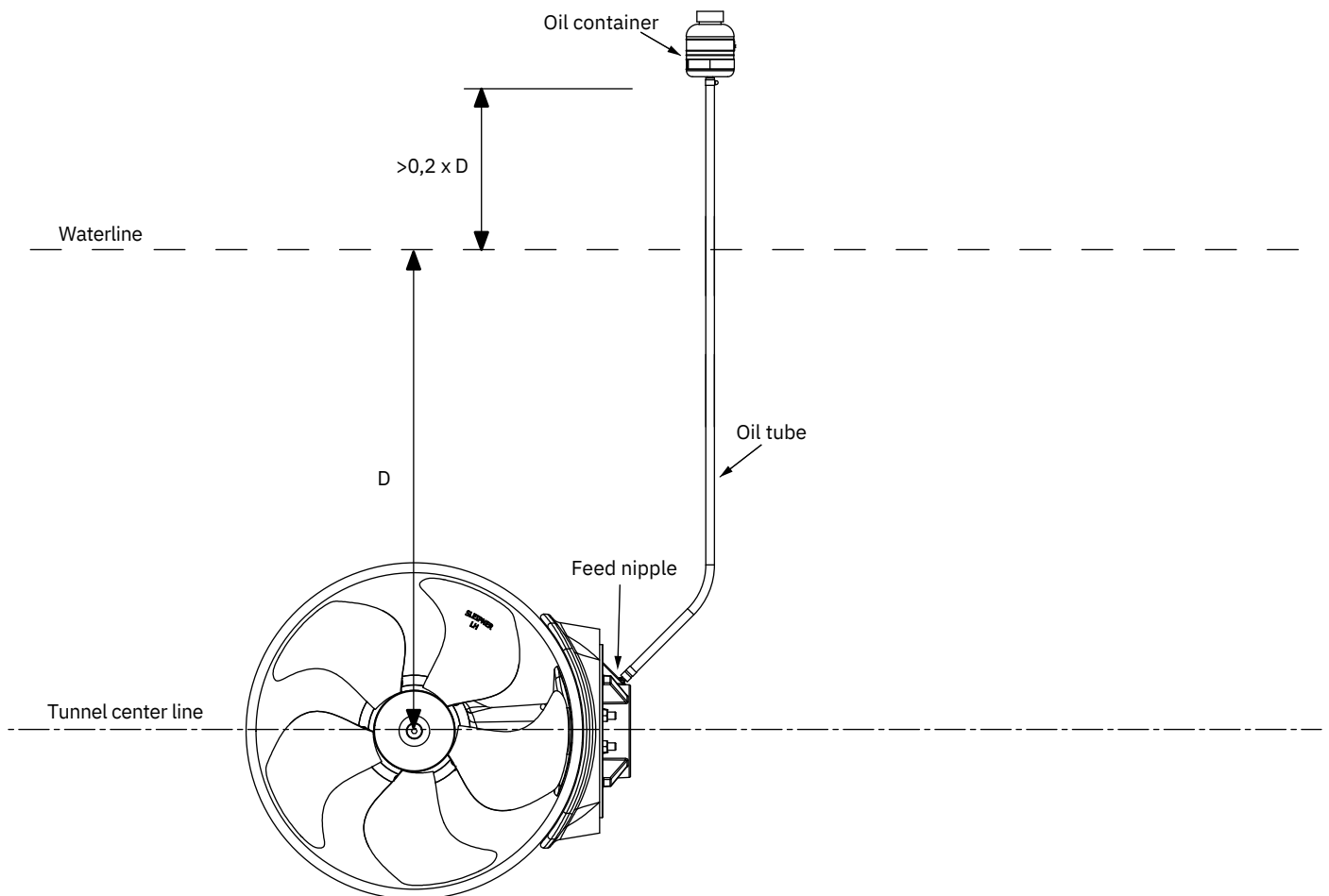

MG_0046

For **Variable-frequency Drive** installation please refer to the Installation Guide accompanying the VFD device.

Or download the ABB online manuals:



- ACS580-01 3AXD50000044794
- ACH580-31 3AXD50000044839
- ACS880-01 3AUA50000078093
- ACS880-31 3AXD50000045933

Note: Routing and termination of shield on ACS880 units with common mode filter:

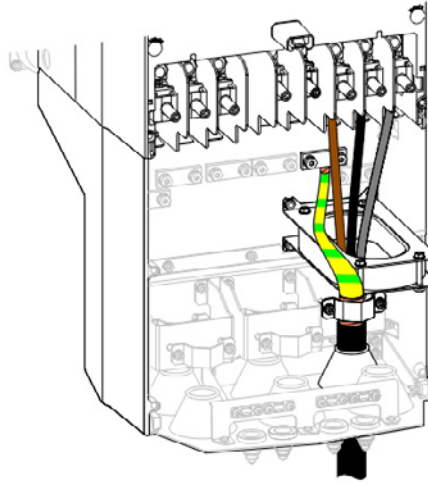
0632

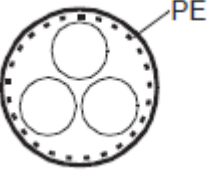
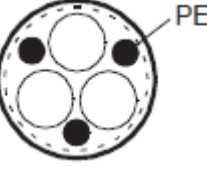

Recommended motor cables

Cable type	Use as input power cabling	Use as motor cabling and as brake resistor cabling
 <p>Symmetrical shielded (or armored) cable with three phase conductors and concentric PE conductor as shield (or armor)</p>	Yes	Yes
 <p>Symmetrical shielded (or armored) cable with three phase conductors and symmetrically constructed PE conductor and a shield (or armor)</p>	Yes	Yes
 <p>Symmetrical shielded (or armored) cable with three phase conductors and a shield (or armor), and separate PE conductor/cable 1)</p>	Yes	Yes

1) A separate PE conductor is required if the conductivity of the shield (or armor) is not sufficient for the PE use.

Item no.	Supply voltage	Max current draw A	Minimum power cable dimensions	
			Temp class 70	Temp class 90
			Multi core mm ²	Multi core mm ²
SAC750/513-x-4	380-440V 3-phase	84	50	25
SAC750/513-x-2	208-240V 3-phase	150	120	70
SAC900/513-x-4	380-440V 3-phase	106	70	50
SAC900/513-x-2	208-240V 3-phase	185	150	95
SAC1100/513-x-4	380-440V 3-phase	134	95	50
SAC950/610-x-4	380-440V 3-phase	90	50	25
SAC1100/610-x-4	380-440V 3-phase	108	70	35
SAC1200/610-x-4	380-440V 3-phase	128	95	50
SAC1300/610-x-4	380-440V 3-phase	143	95	70
SAC1400/610-x-4	380-440V 3-phase	160	120	70

MC_1156

CAUTION

Installation must be done by certified electricians, and according to the VFD install manual. This table is a general recommendation and installer must consider relevant regulations, temperature conditions and cable lengths

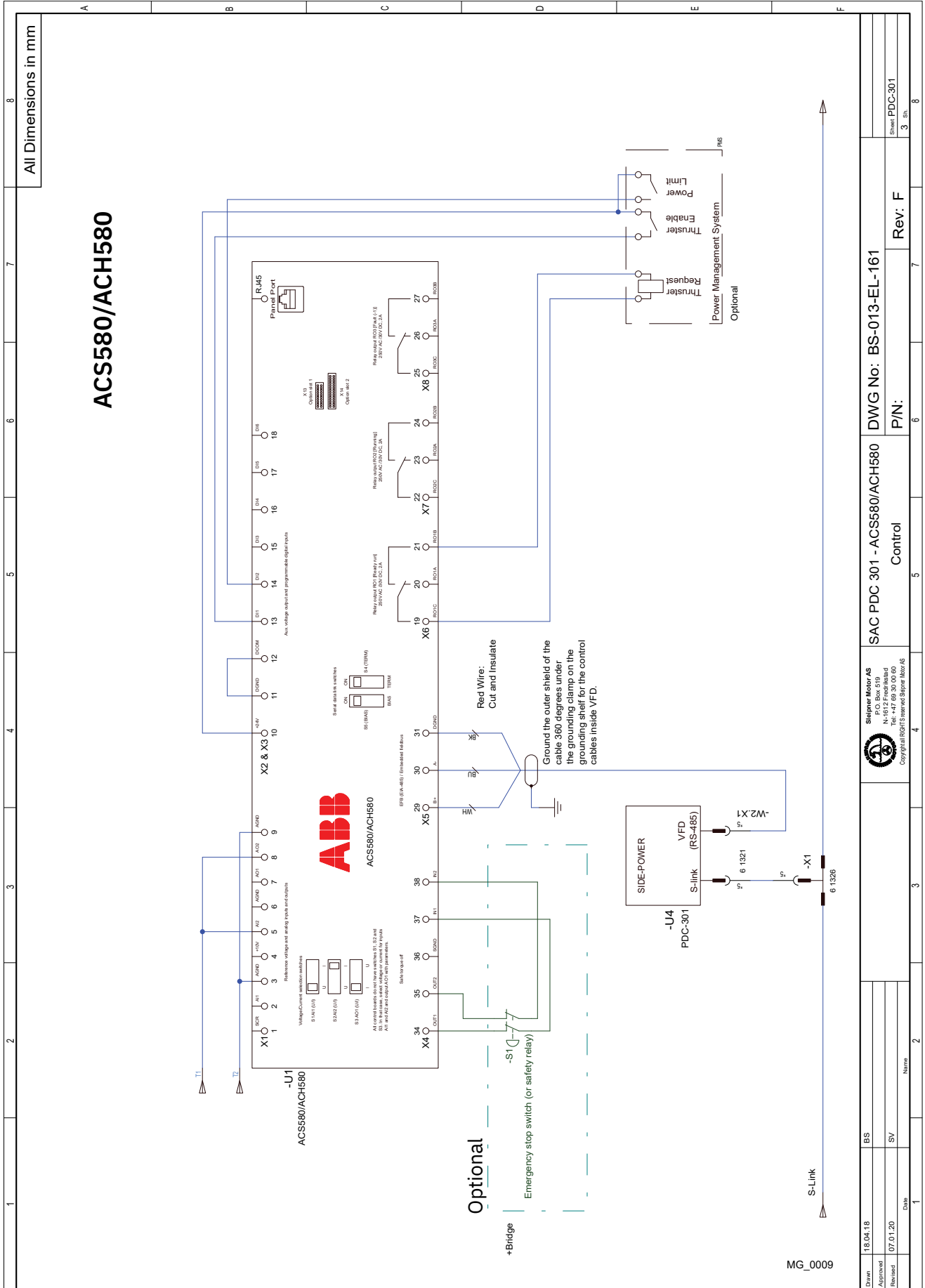

Drawn	18.04.18	BS	SAC PDC 301 - ACS580/ACH580	DWG No: BS-013-EL-161	Rev: F	Sheet PDC-301
Approved						3 Sh.
Revised	07.01.20	SV	Control	P/N:		
Date		Name				

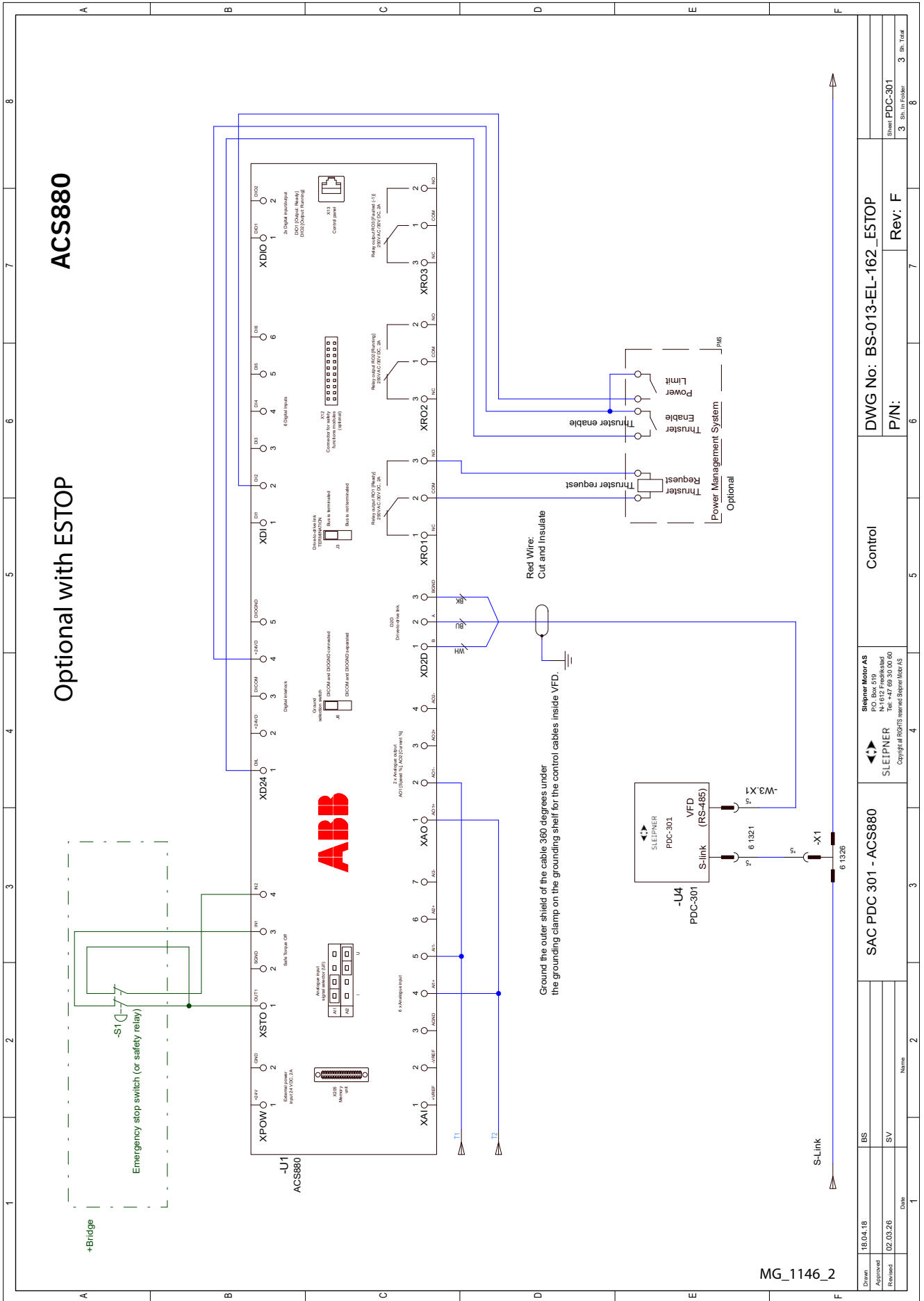

MG_1146_2

Drawn	18.04.18
Approved	BS
Reviewed	SV
Date	
Name	

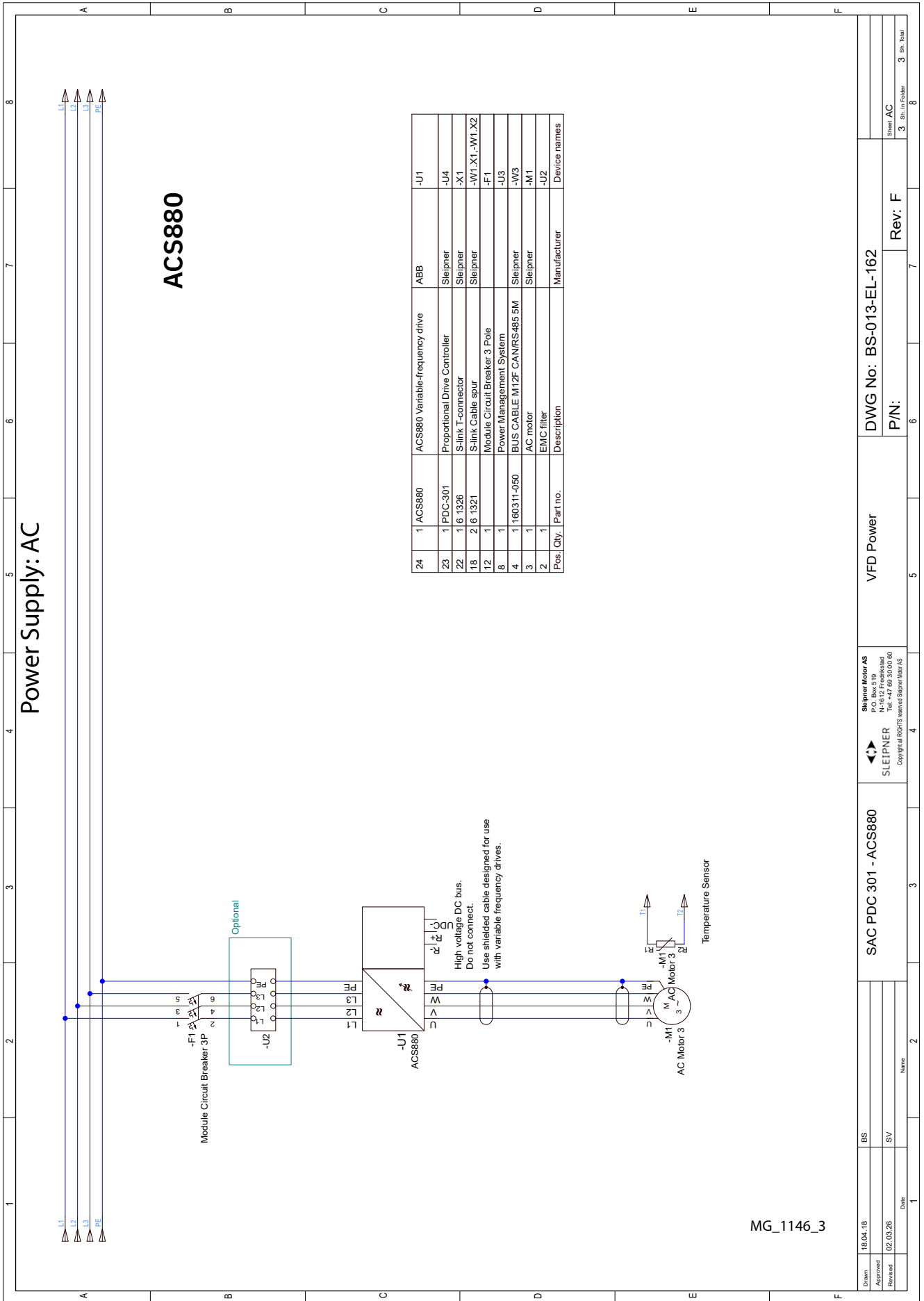

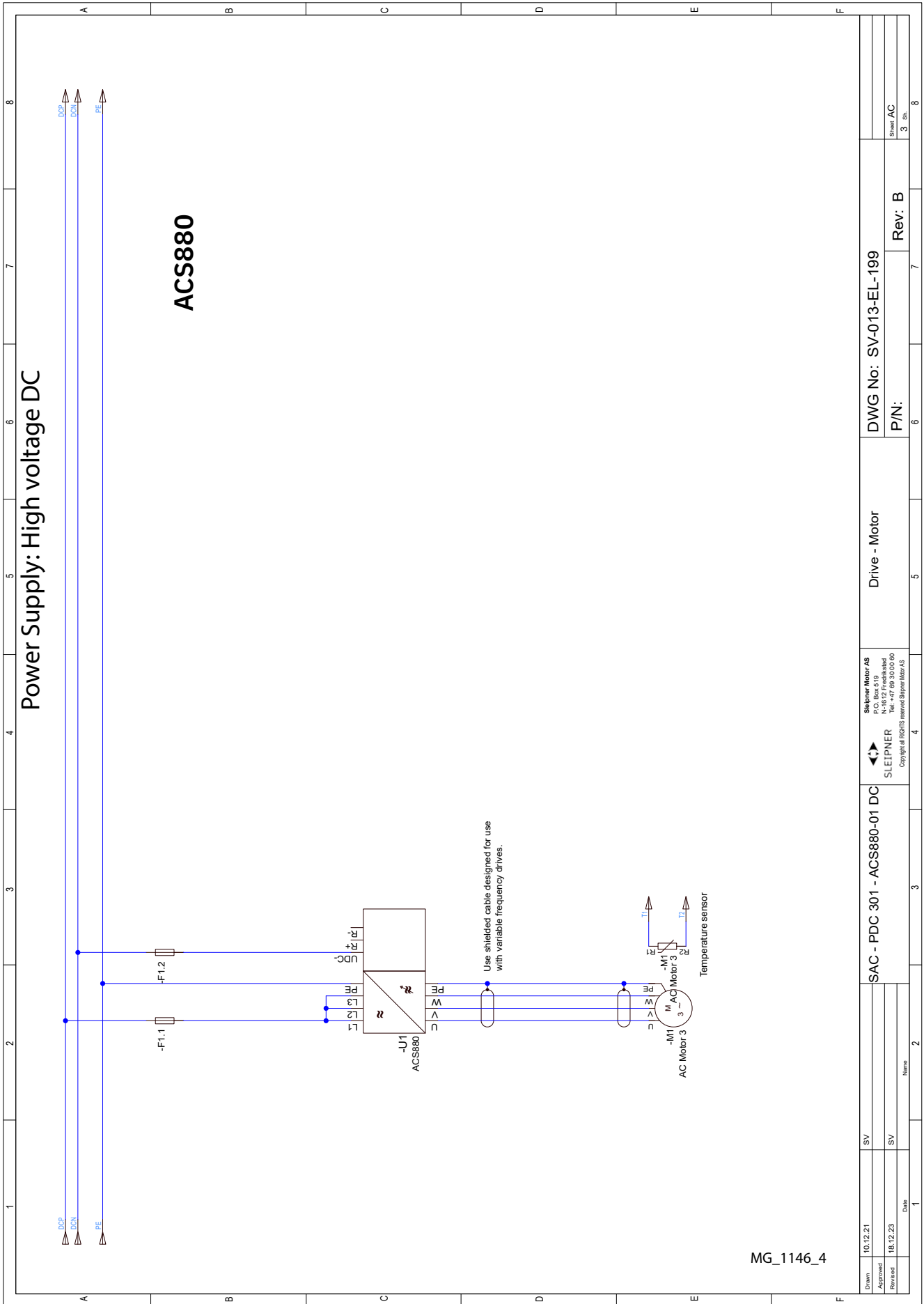

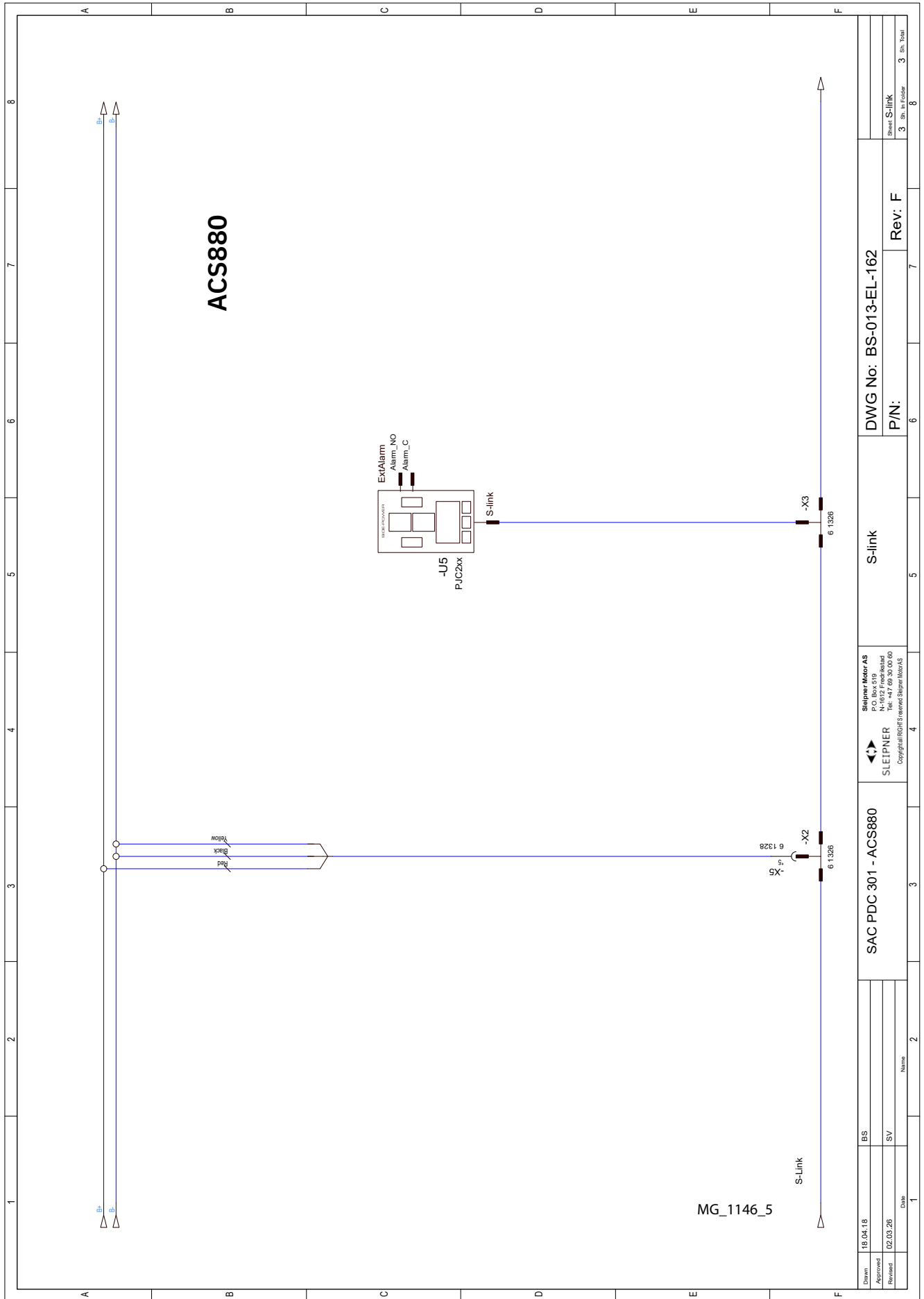

The PDC 301 proportional drive controller controls the speed and direction signals for the Variable Frequency Drive (VFD) controlling the electric motor. The user control panels transmit this information to the Controller. VFD status and alarm signals, as well as motor speed feedback is received by the PDC 301 and transmitted to the control panels. **(NB: Installation of the VFD must be done by certified electricians, and according to the VFD installation manual.)**

PDC-301 Controller Technical Specifications	
Supply Voltage	9-31V, Powered from the S-link bus
Power consumption	Less than 1W
Operating temperature	-20°C to 70°C (-4°F to 158°F)
Weight	150g/5.3oz
IP Rating	IP-66

S-Link LED status	
Continuous GREEN	Flashing GREEN
S-link communication is OK	No S-link communication
VFD (RS-485) LED status	
Continuous GREEN	Flashing GREEN
communication with VFD is OK	No communication with VFD

MC_0157



MG_0170

Before the first start ensure the propeller shaft rotates freely, and the thruster is safe to operate. **(NB: The ABB variable frequency drive-controlling the motor will perform a motor ID run on the first start.)**
If the control panel displays the “Set-up Assistant”, select “Exit & don’t show at power up”. The drive is already correctly set up before delivery.

1. Place the VFD in local mode on the front panel by pressing the Loc/Rem button. **(NB: The panel should display Local in the upper left corner.)**
2. Start the drive by pressing the Start button on the VFD panel. The panel will indicate that the ID run is in progress and when it has completed. **(NB: This procedure takes a few seconds.)**
3. Press the Stop button when the ID run is complete.
Configure the drive in Remote mode by pressing the Loc/Rem button. After being placed in Remote mode, the thruster can now operate from the Side-Power joystick panels.

(NB: The PDC-301 drive controller is configured as a bow thruster By default. If operated as a stern thruster or in a catamaran configuration, change the thruster instance from the setup menu of the PJC-2xx/PJC-4xx control panel.)

PMS (Power Management System) ~ Optional:

The thruster control system comes preconfigured for the thruster, but additional configuration is required if integration to a Power Management System.

For ACS580 to activate PMS, the VFD parameter 20.12 “Run enable 1 source” must be set to DI1. It is set by default to “Selected”.

For ACH580 to activate PMS, the VFD parameter 20.40 “Run permissive” must be set to DI1. It is set by default to “Not used”.

For ACS880 to activate PMS, the VFD parameter 20.12 “Run enable 1 source” must be set to DIIL. It is set by default to “DIIL”.

When any panel is turned on the PDC-301 will activate the relay output on the VFD for Thruster power request from PMS. Then when the PMS is ready it sends a Thruster Enable signal back to the VFD as a “ready signal” before the thruster can run. If the PDC-301 is not getting the “Thruster Enable” signal within 60 seconds, it will fault displaying fault code 36101.1.200 VFD PMS TIMEOUT. If the Thruster enable signal is lost while the thruster is running it will fault displaying fault code 36101.1.204 PMS SIGNAL LOST.

MC_0412

Motor protection functions:

Dynamic thrust limitation:

If the electric motor winding temperature exceeds 130°C, the PDC 301 limits the maximum thrust output. The maximum thrust permitted will decrease proportionally to increasing temperatures higher than 130°C. **(NB: Joystick panel will give an alert when the temperature exceeds 130°C. In this situation, the thruster can still be operated. Motor temperature can be monitored from the PJC panel)**

Motor over temperature shut-down:

If the electric motor winding temperature exceeds 150°C the motor will stop and 'Motor Over-temp' is displayed on the connected control panels. The thruster is prohibited from running until the motor has cooled down.

Limited Power ~ Optional:

By default, the digital input DI2 on the VFD is set to limit the power by limiting the VFD torque when the input is +24V. When in "Limited Power" mode a flashing "LIMITED POWER" text alert will display on the PJC panel.

To change the torque level, change these VFD parameters:

30.23	Minimum torque 2	-50.0 % (default value)
30.24	Maximum torque 2	50.0 % (default value)

Emergency Stop:

Where an Emergency Stop circuit is required, Sleipner recommend implementing the circuit based on the ABB STO(Safe Torque Off) function.

This safety circuit require two parallel circuits switching simultaneously. The circuit diagram can be found in figure xx.

For further information on the STO circuit, refer to ABB HW manual for the drive model installed, where the Safe Torque Off function is described in detail.

MC_0158

S-Link is a CAN-based control system used for communication between Sleipner products installed on a vessel. The system uses BACKBONE Cables as a common power and communication bus with separate SPUR Cables to each connected unit. Only one S-Link POWER cable shall be connected to the BACKBONE Cable. Units with low power consumption are powered directly from the S-Link bus.

Main advantages of S-Link system:

- Compact and waterproof plugs.
- BACKBONE and SPUR Cables have different colour coding and keying to ensure correct and easy installation. BACKBONE Cables have blue connectors and SPUR Cables have green connectors.
- Different cable lengths and BACKBONE Extenders make the system scalable and flexible to install.

Installation of S-Link cables:

Select appropriate cables to keep the length of BACKBONE- and SPUR Cables to a minimum. In case of planned installation with total BACKBONE Cable length exceeding 100 meters please consult your local distributor. The S-Link cables should be properly fastened when installed to avoid sharp bend radius, cable chafing and undesired strain on connectors. Locking mechanism on connectors must be fully closed. To ensure long lifetime, cables, T-Connectors and Extenders should not be located so that they are permanently immersed in water or other fluids. It is recommended to install cables in such a way that water and condensation do not flow along the cables into the connectors. This can be done for example by introducing a u-shape bend before the cable enters the product connector.

Ideally, the POWER Cable should be connected to the middle of the BACKBONE bus to ensure an equal voltage drop at both ends of the BACKBONE Cable. The yellow and black wire in the POWER Cable shall be connected to GND and the red wire connected to +12VDC or +24VDC.

To reduce the risk of interference, avoid routing the S-Link cables close to equipment such as radio transmitters, antennas or high voltage cables. The backbone must be terminated at each end with the END Terminator.

SPUR cables can be left unterminated to prepare for the installation of future additional equipment. In such cases, ensure to protect open connectors from water and moisture to avoid corrosion in the connectors.

MC_0120N

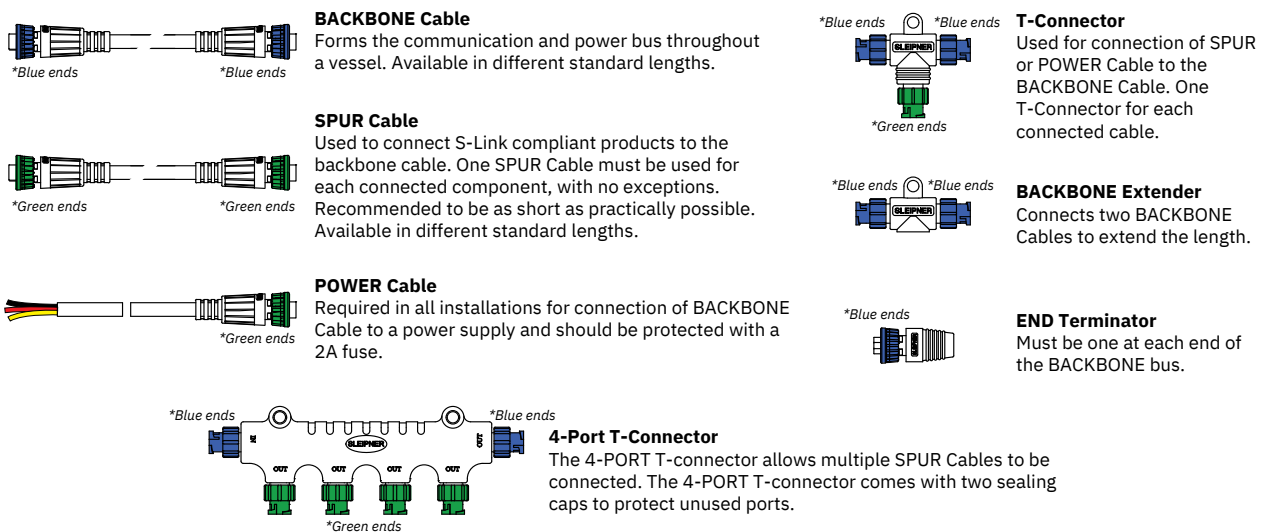

S-Link installation example

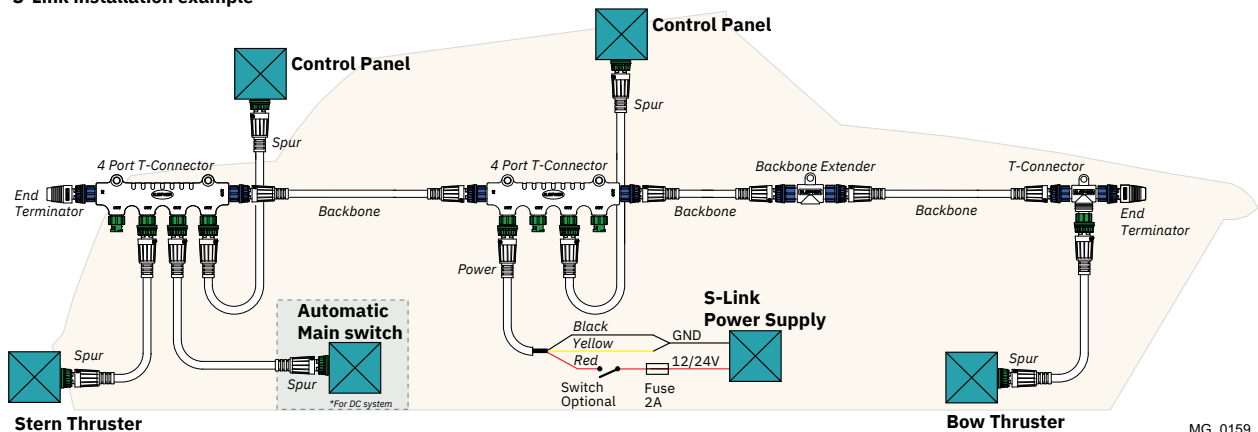

MG_0159

Control panel cable installation

- All Sleipner control panels can be used in any combination.
- All control panels can be installed using:
 - Y-connectors - for standard on/off
 - T-connectors - for S-Link proportional power system.

(NB: If two or more control panels are operated at the same time in opposite directions, the electronic control box will stop the thruster until it receives a single signal or thrust in one direction.)

- Sleipner on/off equipment it is entirely “plug & play” and require no additional configuration setup.

See the Control panel manual for more information.

MC_0041

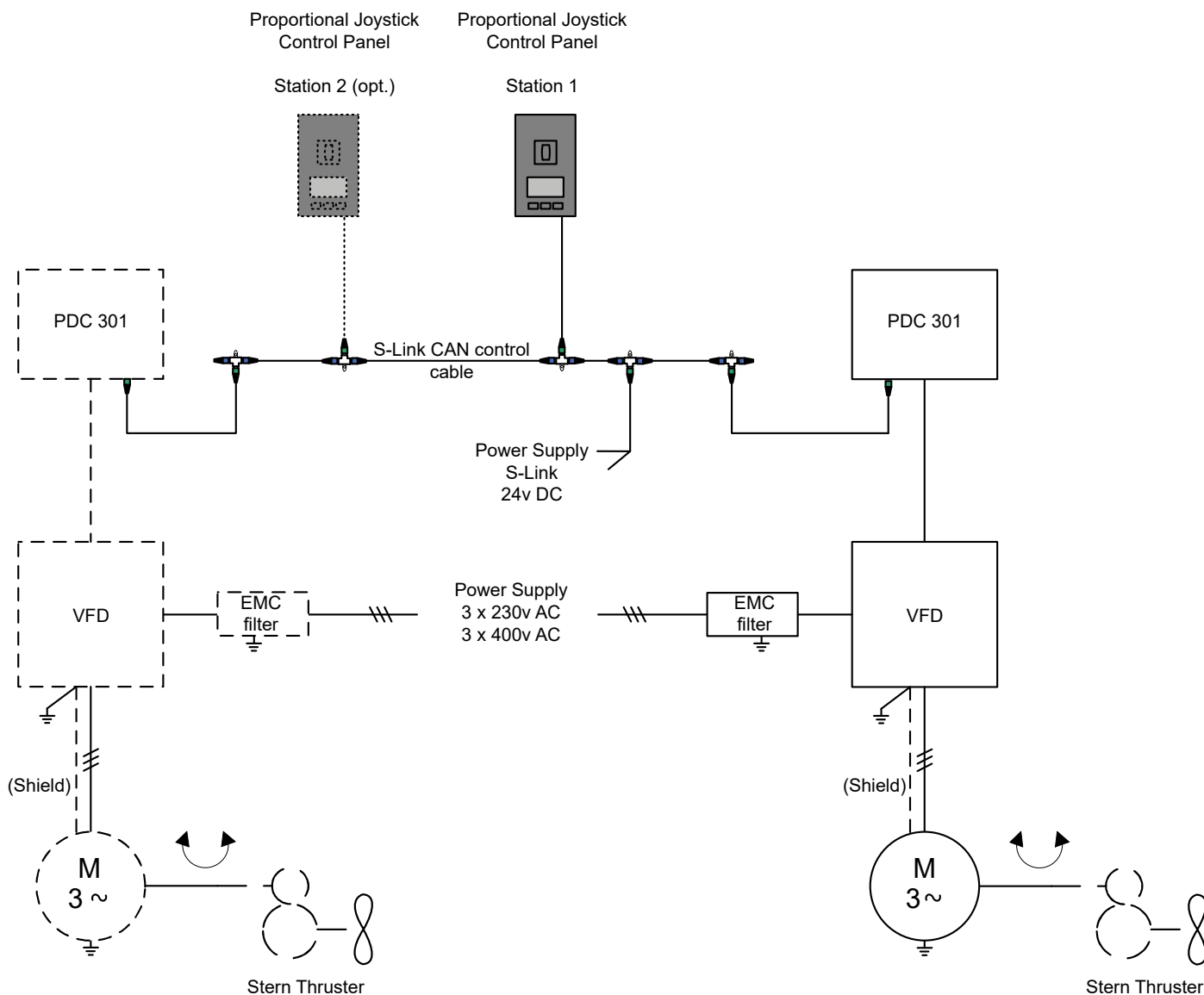

MG_0169

For **Control Panel** installation please refer to the Installation Guide accompanying the control panel to be installed.

MC_0398



- Propeller is fastened correctly to the shaft.
- Propeller turns freely in tunnel.
- Lower-unit is filled with gear oil.
- Oil-drain screw is tightened and the copper seal is present.
- The anode holding screw is tightened well with thread glue.
- Anti-fouling have been applied to the gear house and propeller but NOT on the anode or the gear house lid where the propeller is fastened.
- Oil tank is fitted above the waterline as required and filled with gear oil.
- Correct drive direction as per control panel.
- The bolts holding the gear house and motor bracket together are tightened correctly.
- The bolts holding the motor to its bracket are tightened correctly.

MC_0160

The thruster has been installed as per the instructions in this manual and all points in checklist above have been controlled.

Signed:

Date:

Extra pre-delivery tests by installer / yard who does not use other quality control systems !

Thruster type:

Serial number:.....

Date of delivery:.....

Correct drive direction as per control panel:

The compartment for the thruster has been isolated from general bilge water and has no obvious or suspected risks for flooding:

.....
.....
.....

Other comments by installer:

.....

Find your local certified dealer through our global network to receive expert service and support. Visit our website for more information: www.sleipnergroupp.com/support



Product Spare Parts and Additional Resources

For additional supporting documentation, visit our website at www.sleipnergroupp.com and locate your specific Sleipner product.



Patents

At Sleipner we continually reinvest to develop and offer the latest technology in marine advancements. To see the many unique designs we have patented, visit our website: www.sleipnergroupp.com/patents



MC_0024

1. Sleipner Motor AS (The “Warrantor”) warrants that the equipment (parts, materials, and embedded software of products) manufactured by the Warrantor is free from defects in workmanship and materials for purpose for which the equipment is intended and under normal use and maintenance service (the “Warranty”).
2. This Warranty is in effect for two years (Leisure Use) or one year (Commercial and other Non-leisure Use) from the date of delivery/purchase by the end user, with the following exceptions:
 - (a) For demonstration vessels, or vessels kept on the water, the dealer is considered as the end user from 6 months after their launch of the vessel;
 - (b) The warranty period starts no later than 18 months after the first launch of the vessel.Please note that the boat manufacturer and dealer must pay particular attention to correct maintenance and service both by the products manuals as well as general good practice for the location the boat is kept in the period the boat is in their care. In cases where the 6 and 18 months grace periods for boat builders and dealers are passed, it is possible to obtain a full warranty upon inspection and approval of the warrantor or such representative.
3. Certain parts, classified as wearable or service parts, are not covered by the warranty. A failure to follow the required maintenance and service work as described in the product manual render all warranty on parts or components directly or indirectly affected by this void. Please also note that for some parts, time is also a factor separately from actual operational hours.
4. This Warranty is transferable and covers the equipment for the specified warranty period.
5. The warranty does not apply to defects or damages caused by faulty installation or hook-up, abuse or misuse of the equipment including exposure to excessive heat, salt or fresh water spray, or water immersion except for equipment specifically designed as waterproof.
6. In case the equipment seems to be defective, the warranty holder (the “Claimant”) must do the following to make a claim:
 - (a) Contact the dealer or service centre where the equipment was purchased and make the claim. Alternatively, the Claimant can make the claim to a dealer or service centre found at www.sleipnergroun.com. The Claimant must present a detailed written statement of the nature and circumstances of the defect, to the best of the Claimant’s knowledge, including product identification and serial nbr., the date and place of purchase and the name and address of the installer. Proof of purchase date should be included with the claim, to verify that the warranty period has not expired;
 - (b) Make the equipment available for troubleshooting and repair, with direct and workable access, including dismantling of furnishings or similar, if any, either at the premises of the Warrantor or an authorised service representative approved by the Warrantor. Equipment can only be returned to the Warrantor or an authorised service representative for repair following a pre-approval by the Warrantor’s Help Desk and if so, with the Return Authorisation Number visible postage/shipping prepaid and at the expense of the Claimant.
7. Examination and handling of the warranty claim:
 - (a) If upon the Warrantor’s or authorised service Representative’s examination, the defect is determined to result from defective material or workmanship in the warranty period, the equipment will be repaired or replaced at the Warrantor’s option without charge, and returned to the Purchaser at the Warrantor’s expense. If, on the other hand, the claim is determined to result from circumstances such as described in section 4 above or a result of wear and tear exceeding that for which the equipment is intended (e.g. commercial use of equipment intended for leisure use), the costs for the troubleshooting and repair shall be borne by the Claimant;
 - (b) No refund of the purchase price will be granted to the Claimant, unless the Warrantor is unable to remedy the defect after having a reasonable number of opportunities to do so. In the event that attempts to remedy the defect have failed, the Claimant may claim a refund of the purchase price, provided that the Claimant submits a statement in writing from a professional boating equipment supplier that the installation instructions of the Installation and Operation Manual have been complied with and that the defect remains.
8. Warranty service shall be performed only by the Warrantor, or an authorised service representative, and any attempt to remedy the defect by anyone else shall render this warranty void.
9. No other warranty is given beyond those described above, implied or otherwise, including any implied warranty of merchantability, fitness for a particular purpose other than the purpose for which the equipment is intended, and any other obligations on the part of the Warrantor or its employees and representatives.
10. There shall be no responsibility or liability whatsoever on the part of the Warrantor or its employees and representatives based on this Warranty for injury to any person or persons, or damage to property, loss of income or profit, or any other incidental, consequential or resulting damage or cost claimed to have been incurred through the use or sale of the equipment, including any possible failure or malfunction of the equipment or damages arising from collision with other vessels or objects.
11. This warranty gives you specific legal rights, and you may also have other rights which vary from country to country.



SLEIPNER

Ocean born. Tech bred.

SLEIPNER MOTOR AS

P.O. Box 519

N-1612 Fredrikstad

Norway

www.sleipnergroup.com

Made in Norway

© Sleipner Motor AS, All rights reserved

The information given in the document was right at the time it was published. However, Sleipner Motor AS cannot accept liability for any inaccuracies or omissions it may contain. Continuous product improvement may change the product specifications without notice. Therefore, Sleipner Motor AS cannot accept liability for any possible differences between product and document. Learn more about our products at www.sleipnergroup.com