

Keep this
manual onboard!



User Manual

Including Installation For Control Panels

86-08950, 86-08955



86-08950



86-08955

SLEIPNER GROUP

P.O. Box 519

N-1612 Fredrikstad

Norway

www.sleipnergroup.com

DOCUMENT ID: 6666

REVISION: 5

DATE: 2024

LANGUAGE: EN



To download your language go to www.sleipnergroup.com

Contents

User Manual

General Operation Consideration and Precaution Guidelines	3
Windlass Operation	4
Control Panel.....	5
End-Stop Sensor	5
Control Panel.....	6

Installation Manual

Responsibility of the Installer.....	7
General Installation Considerations and Precautions for Windlass.....	7
Control Panel Installation.....	8
Measurements.....	9
Visual Wiring Diagram	10

Service and Support.....	12
Product Spare Parts and Additional Resources.....	12
Warranty Statement.....	12

General Operation Consideration and Precaution Guidelines

For Windlass systems

Never use a windlass close to somebody in the water, an unexpected drop of the anchor can cause serious injuries.

It is the owner/ captain/ other responsible parties full responsibility to assess the risk of any unexpected incidents on the vessel.

- Keep your distance to the windlass, the anchor line, anchor and anchor brackets during operation.
- While operating the anchor maintain observation of the rope or chain during handling.
- Ensure anyone using the windlass knows how to operate it.
- Be aware when the anchor are raised as it can bring unwanted debris up from the bottom, potentially damaging your boat. **(NB: If the windlass is straining as the anchor is raised, stop for a few seconds and let the boat gain up momentum before continuing the raise.)**
- If the anchor is stuck, release some anchor line/chain and attach it to a cleat before using the boat to pull the anchor free. The windlass is not designed for loads beyond the specified pull capabilities.
- The anchor MUST ALWAYS be secured to the boat while under way. Use the security line or other means to prevent unintentional anchor drop.
- Children must not operate the windlass.
- Careless use can cause damage or injury!
- Keep the engine running during windlass operation to ensure good battery capacity.
- Sleipner Motor AS is not responsible for damage or injury caused by the use of our windlass systems.
- While dropping anchor, do not push the "UP" button until the anchor is resting at the seabed.

! Please refer to the graphic for special considerations relating to your model !

Docking with remote control

RC-21E, RC-22E & RC-23E

1. Make sure the boat engine is running during anchoring.
2. Decide where you want to drop anchor.
3. Check that the safety line on the anchor has been loosened.
4. Turn ON the main switch of the windlass.
5. When main switch for the windlass has been switched off, you must press down both ON buttons on the remote, before pressing DOWN button to release the anchor.

Docking with fixed switch panel

1. Press the down button for at least 1 sec.
2. The anchor will drop.
3. The windlass is now released and the rope will run out in step with the progress of the boat towards land.
4. Tie up the boat.

(NB: The windlass will always wind in slowly before it reaches to full speed. From software 1.008 can the windlass wind in with reduced speed by double clicking the UP button.)

Departing

1. Start the boat engine.
2. Turn on the main switch.
3. Release the mooring from land.
4. Activate the windlass.
5. Keep the up button depressed, and the windlass will pull the boat away from land. The windlass will pull the anchor up at full speed until the first auto stop is activated.

After the first auto stop:

1. Release the up button, press again and keep depressed.
2. The windlass will continue to raise the anchor slowly until the second auto stop is activated, stopping the windlass completely.
3. The anchor will then be correctly seated in the anchor bracket.
4. Attach the safety line to the anchor.
5. Turn off the main switch of the windlass.
6. Have a pleasant sailing!

(NB: This ONLY applies for rope anchor line windlasses and requires the anchor line to be correctly fitted with end-stop sensor rings.)

IMPORTANT

Keep an eye on the anchor when it leaves the water and seats in the anchor bracket. This will allow you to stop the windlass and prevent damage if the anchor pulls up foreign objects from the seabed.

(NB: If the windlass is straining while raising the anchor, it would be a good idea to run the windlass in periods. Once the boat has begun to move backwards, you can release the up button and then run the windlass in periods.)

Control Panel



Control Unit

The windlass controller 150800 is a full direction and PVM- speed controller with Amp and voltage monitoring. It can control the direction of the windlass and reduce the speed without reducing the pulling power of the system

(NB: This allows for smoother operation (ramped motor start) and access to features like Slow pull speed.)

WARNING
For safety ALWAYS secure the anchor with a suitable safety line when not in use.



REMOTE CONTROL



RCT-21

RCT-22

RCT-23

Wireless remote control

The remote is waterproof and floats if dropped into the water. It has under normal conditions a radio range of 15m.

Remote control is turned ON by pressing both ON buttons.

To ensure a long battery lifetime, the remote control switches off automatically 4 min. after the last button was pressed.

(NB: Remote and receiver is normally connected and ready to use. See own manual for more information and variants.)

Control Panels

Activating raises Anchor/ Windlass

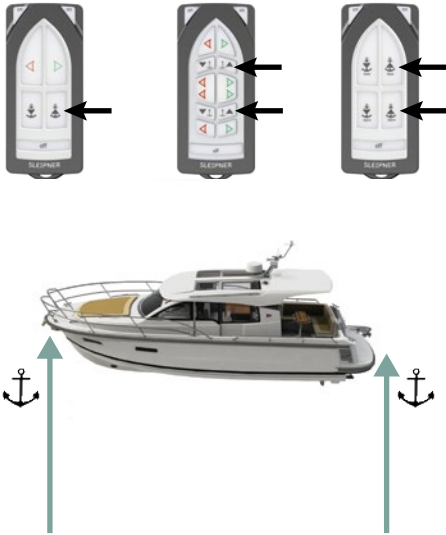

Activating lowers Anchor/ Windlass

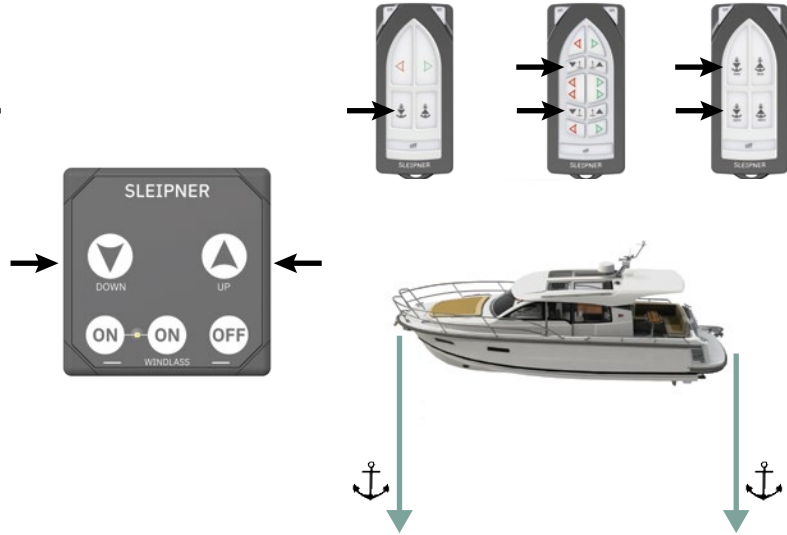

Anchor UP

When the anchor has dropped to the seabed, press the “up” button to tighten the slack. The windlass will continue to winch in as long as you keep the “up” button depressed. If the remote control has switched off automatically (*i.e. if you have not pressed a button for more than 4 min*) you must first switch ON, then press ‘UP’ start to wind in the anchor line/chain. The windlass always starts to operate at reduced speed before increasing to full speed.

Anchor DOWN

When the remote control is switched on, you can drop the anchor by pressing the “down” button. Keep this button depressed for at least 1 second to drop the anchor. The windlass will then run out slowly in the beginning to ensure the correct release function.

IMPORTANT

Always turn OFF the power to the windlass when it is not being operated. The anchor must always be secured to the boat while the boat is sailing. Use the safety line supplied.

Double-tap Anchor UP feature

If all power has been removed from the windlass (*i.e. powered off after leaving the vessel or during an overnight anchoring*) the internal sensor will no longer remember the current status of the anchor's position (Up or DOWN). Instead of releasing the slack on the anchor completely Double-tap UP to activate the slow retract of the anchor. (**NB: This can help safely navigate away from objects when un/ mooring the vessel.**)

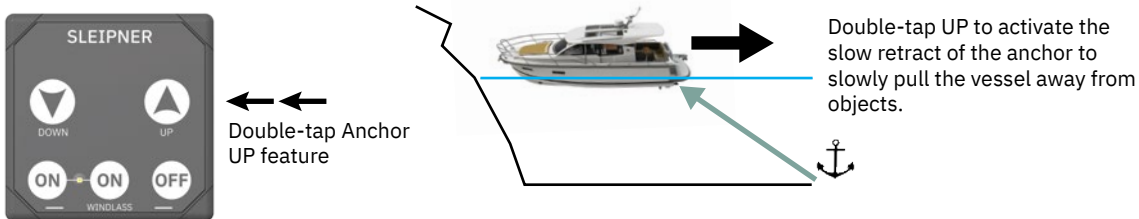

WARNING

ALWAYS secure the anchor with a suitable safety line when not in use. The windlass cannot be considered a fixed point. (Underway the anchor line can potentially slide in the housing gypsy. An unintended mechanical release of the gypsy can not be guaranteed.)

End-Stop Sensor

This system is designed so the windlass automatically stops pulling when the anchor reaches the boat. If normally adjusted it will stop when the anchor is hanging 0,5-1 m under the surface. (**NB: This allows for time to finish any close quarter maneuverer, get lines and other equipment used at anchor in order, inspect the anchor to ensure it is free of cables, trolleys or whatever else you might catch.**)

Also by sailing slowly it is possible to flush the anchor free of sand, seaweed or sediments before the final operation to raise anchor on board the boat.

After the first stop is detected and pull is resumed by repressing the “up” again and the controller will pull the anchor in at reduced speed and with a lower allowable pull until the second stop is registered. At this point, the anchor should rest in the bracket without unnecessary high tension on the rope, windlass, fasteners etc.

Control Panel

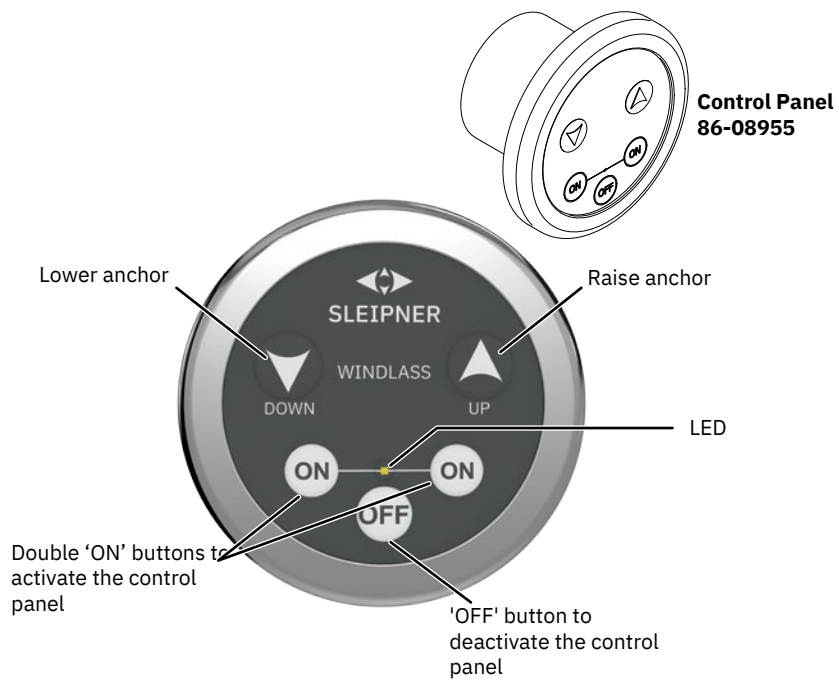
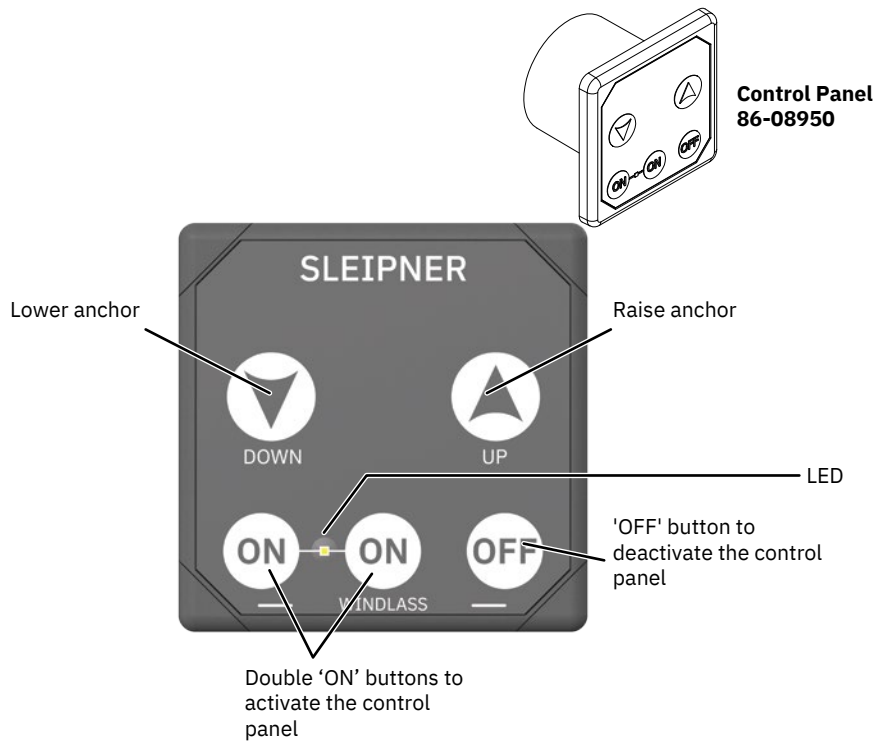

Responsibility of the Installer

MC_0038

The installer must read this document to ensure necessary familiarity with the product before installation.

Instructions in this document cannot be guaranteed to comply with all international and national regulations. It is the responsibility of the installer to follow all applicable international and national regulations when installing Sleipner products.

The recommendations given in this document are guidelines ONLY, and Sleipner strongly recommends that advice is obtained from a person familiar with the particular vessel and applicable regulations.

This document contains general installation instructions intended to support experienced installers. If you are not skilled in this type of work, please contact professional installers for assistance.

If required by local regulation, electrical work must be done by a licensed professional.

Appropriate health and safety procedures must be followed during installation.

Faulty installation of Sleipner products will render all warranties given by Sleipner Motor AS.

Ensure appropriate access to Sleipner products during installation planning for service, inspection and component replacement.

General Installation Considerations and Precautions for Windlass

MC_0424

- Always use original Sleipner rope. **(NB: While dropping anchor, do not push the "UP" button until the anchor is resting at the seabed.)**
- Windlass and accessories must be installed and used in a manner that will not cause damage or injury.
- Do not mount any windlass parts in hazardous environments. **(I.e. flammable fumes or gases.)**
- Control unit 150800 unit is NOT protected from water ingress, it must be installed in a dry area and not exposed for water.
- Windlass motor installations that are exposed to humidity MUST be surface protected with Tectyl or similar.

! Please refer to the graphic for special considerations relating to your model !

Find a suitable location for the control panel where it does not obstruct or is obstructed by other devices. Install the control panel on a flat surface where it is easy to use.

1. Use the supplied cut-out template to mark the area to remove on your control dash.
2. Cut out the area per template for the control panel. **(NB: If the front surface around your cut out is jagged or chipped, use a sealant to assist the gasket.)**
3. Place the gasket to the back face of the panel
4. Plug cables into the connectors at the rear of the control panel.
5. Insert the control panel in place and fasten screws.
6. Insert the control panels covering caps.

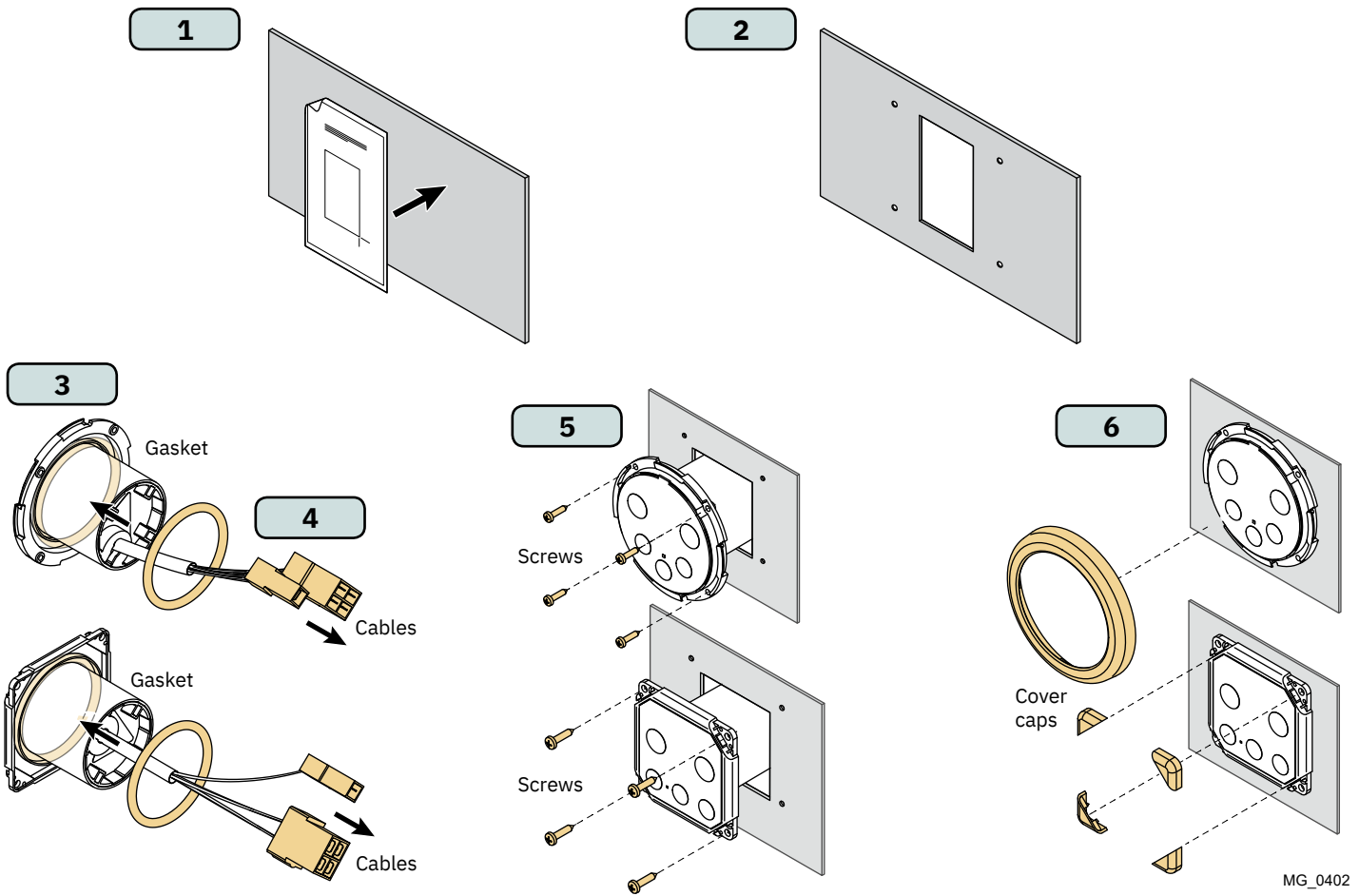

MG_0402

Measurement code	Measurement description	*86-08950		*86-08955	
		mm	inch	mm	inch
ID	Internal panel diameter cut out	51.8	2	51.8	2
D	panel diameter	-	-	86	3.39
H	Panel Height	71	2.8	-	-
W	Panel width	71	2.8	-	-
(a)	Raised height above the dashboard	7	0.26	10.7	0.42
(b)	Depth behind the dashboard (not inc. cables)	41	1.61	39	1.5
(c)	Panel screw hole diameter	3	0.12	2.5	0.10
(d)	Distance between panel screw holes	61	2.4	53	2.09

**Models:
86-08950**

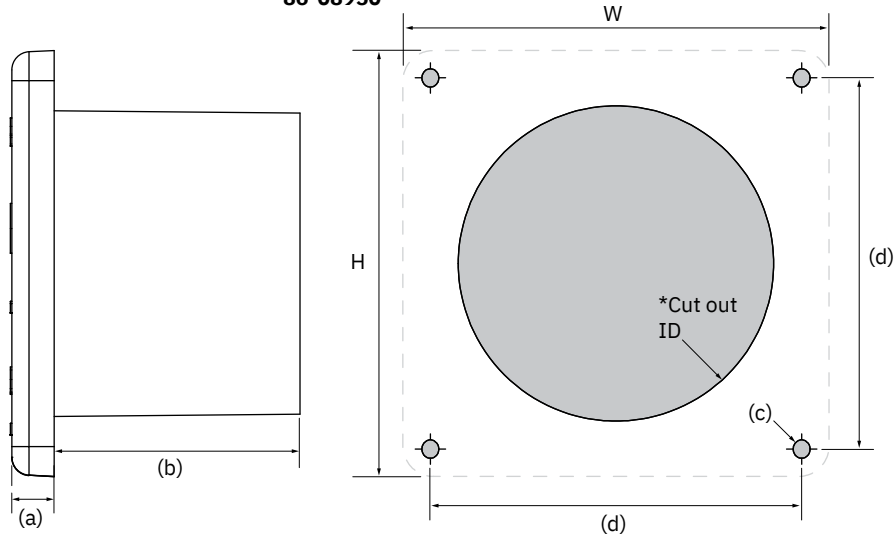

**Models:
86-08955**

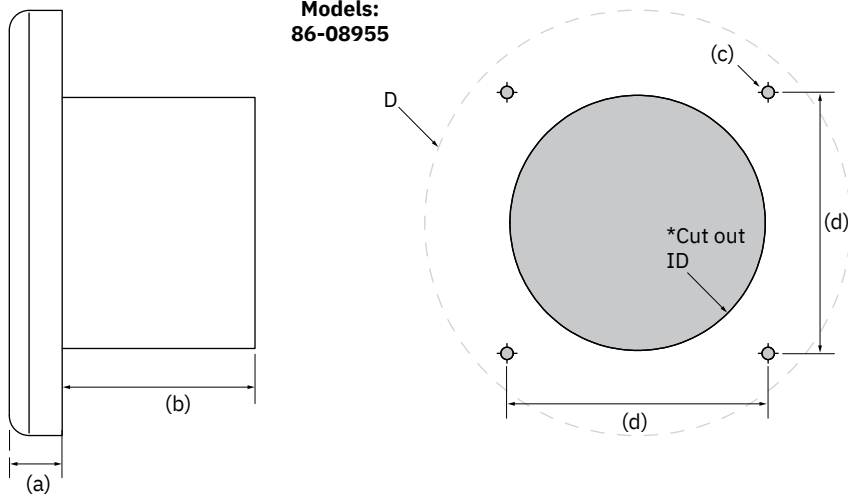

Visual Wiring Diagram

Connecting the motor and battery cables on Maxi windlass

- Connect the four motor cables to the terminals masked A1/A2/D1/D2.
- Connect supply cable from battery negative to the terminal marked B-.
- Connect supply cable from breaker/fuse to the terminal marked B+.
- Connect beaker/fuse to battery main switch.
- Tighten all terminals properly, with a maximum torque of 5Nm. Over-tightening may damage the terminals.
- Leave breaker/fuse disconnected until the installation is completed.

IMPORTANT

If motor runs in the wrong direction, swap cable D1 and D2 on the control unit.

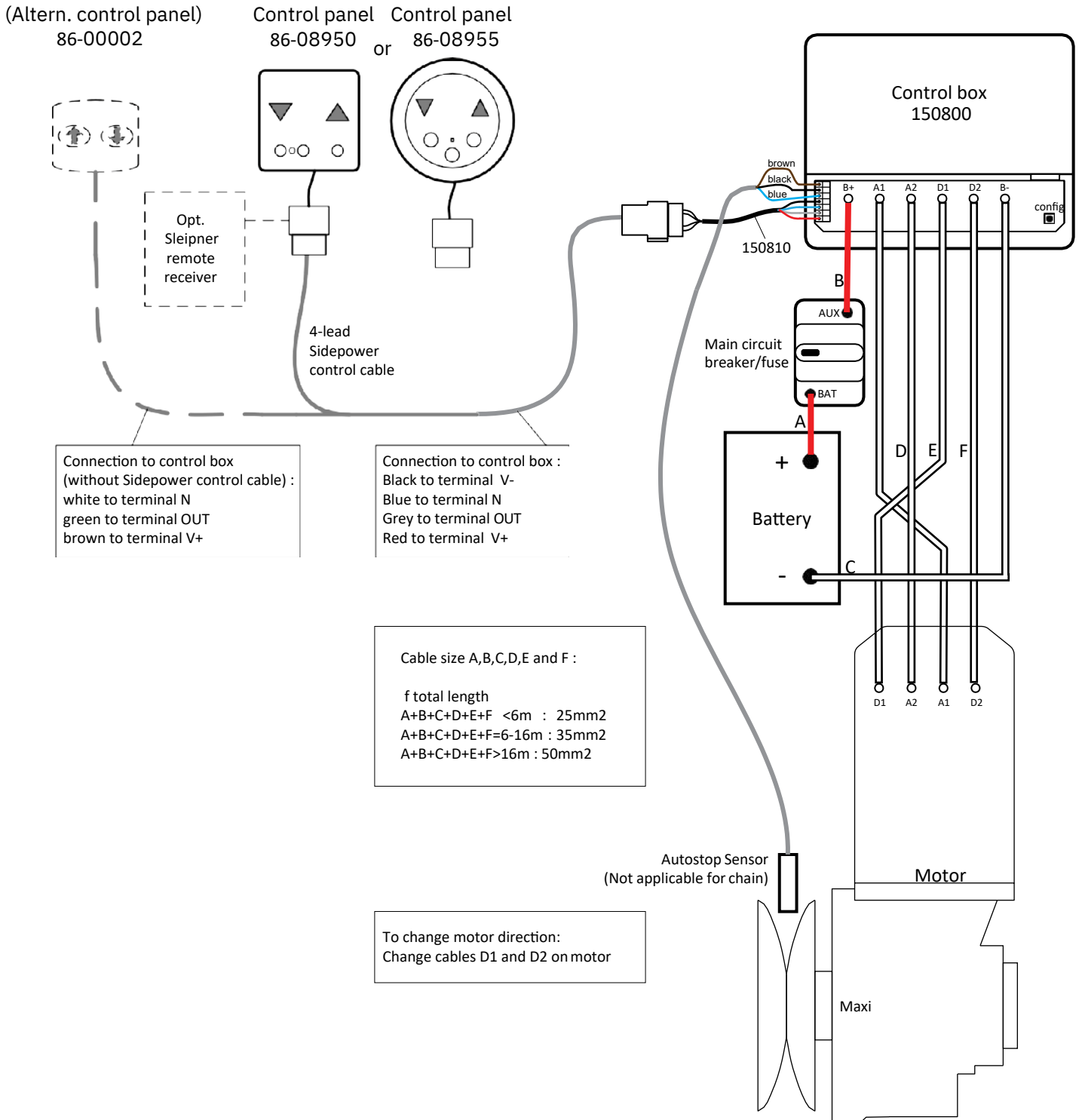

Visual Wiring Diagram

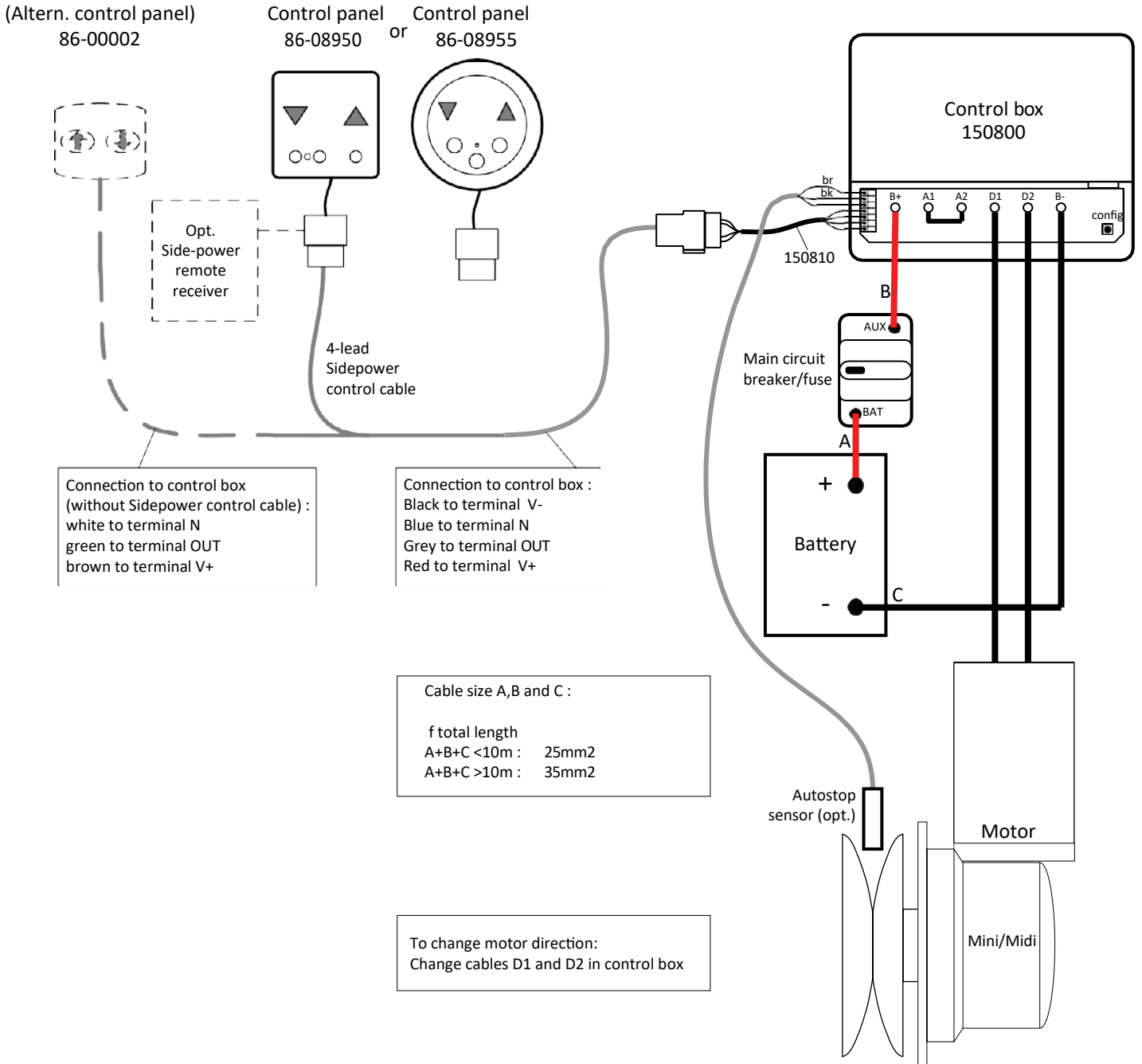

Find your local professional dealer from our certified worldwide network for expert service and support. visit our website www.sleipnergrouper.com/support

Product Spare Parts and Additional Resources

For additional supporting documentation, we advise you to visit our website www.sleipnergrouper.com and find your Sleipner product.

Warranty statement

1. Sleipner Motor AS (The "Warrantor") warrants that the equipment (parts, materials, and embedded software of products) manufactured by the Warrantor is free from defects in workmanship and materials for purpose for which the equipment is intended and under normal use and maintenance service (the "Warranty").
2. This Warranty is in effect for two years (Leisure Use) or one year (Commercial and other Non-leisure Use) from the date of delivery/purchase by the end user, with the following exceptions;
 - (a) For demonstration vessels, or vessels kept on the water, the dealer is considered as the end user from 6 months after their launch of the vessel;
 - (b) The warranty period starts no later than 18 months after the first launch of the vessel.
 Please note that the boat manufacturer and dealer must pay particular attention to correct maintenance and service both by the products manuals as well as general good practice for the location the boat is kept in the period the boat is in their care. In cases where the 6 and 18 months grace periods for boat builders and dealers are passed, it is possible to obtain a full warranty upon inspection and approval of the warrantor or such representative.
3. Certain parts, classified as wearable or service parts, are not covered by the warranty. A failure to follow the required maintenance and service work as described in the product manual render all warranty on parts or components directly or indirectly affected by this void. Please also note that for some parts, time is also a factor separately from actual operational hours.
4. This Warranty is transferable and covers the equipment for the specified warranty period.
5. The warranty does not apply to defects or damages caused by faulty installation or hook-up, abuse or misuse of the equipment including exposure to excessive heat, salt or fresh water spray, or water immersion except for equipment specifically designed as waterproof.
6. In case the equipment seems to be defective, the warranty holder (the "Claimant") must do the following to make a claim:
 - (a) Contact the dealer or service centre where the equipment was purchased and make the claim. Alternatively, the Claimant can make the claim to a dealer or service centre found at www.sleipnergrouper.com. The Claimant must present a detailed written statement of the nature and circumstances of the defect, to the best of the Claimant's knowledge, including product identification and serial nbr., the date and place of purchase and the name and address of the installer. Proof of purchase date should be included with the claim, to verify that the warranty period has not expired;
 - (b) Make the equipment available for troubleshooting and repair, with direct and workable access, including dismantling of furnishings or similar, if any, either at the premises of the Warrantor or an authorised service representative approved by the Warrantor. Equipment can only be returned to the Warrantor or an authorised service representative for repair following a pre-approval by the Warrantor's Help Desk and if so, with the Return Authorisation Number visible postage/shipping prepaid and at the expense of the Claimant.
7. Examination and handling of the warranty claim:
 - (a) If upon the Warrantor's or authorised service Representative's examination, the defect is determined to result from defective material or workmanship in the warranty period, the equipment will be repaired or replaced at the Warrantor's option without charge, and returned to the Purchaser at the Warrantor's expense. If, on the other hand, the claim is determined to result from circumstances such as described in section 4 above or a result of wear and tear exceeding that for which the equipment is intended (e.g. commercial use of equipment intended for leisure use), the costs for the troubleshooting and repair shall be borne by the Claimant;
 - (b) No refund of the purchase price will be granted to the Claimant, unless the Warrantor is unable to remedy the defect after having a reasonable number of opportunities to do so. In the event that attempts to remedy the defect have failed, the Claimant may claim a refund of the purchase price, provided that the Claimant submits a statement in writing from a professional boating equipment supplier that the installation instructions of the Installation and Operation Manual have been complied with and that the defect remains.
8. Warranty service shall be performed only by the Warrantor, or an authorised service representative, and any attempt to remedy the defect by anyone else shall render this warranty void.
9. No other warranty is given beyond those described above, implied or otherwise, including any implied warranty of merchantability, fitness for a particular purpose other than the purpose for which the equipment is intended, and any other obligations on the part of the Warrantor or its employees and representatives.
10. There shall be no responsibility or liability whatsoever on the part of the Warrantor or its employees and representatives based on this Warranty for injury to any person or persons, or damage to property, loss of income or profit, or any other incidental, consequential or resulting damage or cost claimed to have been incurred through the use or sale of the equipment, including any possible failure or malfunction of the equipment or damages arising from collision with other vessels or objects.
11. This warranty gives you specific legal rights, and you may also have other rights which vary from country to country.

Patents

At Sleipner we continually reinvest to develop and offer the latest technology in marine advancements. To see the many unique designs we have patented visit our website www.sleipnergrouper.com/patents

Series of horizontal dotted lines for writing notes.

Area with horizontal dotted lines for notes.

Multiple horizontal dotted lines for writing.

© **Sleipner Group**, All rights reserved
The information given in the document was right at the time it was published. However, Sleipner Group cannot accept liability for any inaccuracies or omissions it may contain. Continuous product improvement may change the product specifications without notice. Therefore, Sleipner Group cannot accept liability for any possible differences between product and document.

Learn more about our products at
www.sleipnergroun.com



SLEIPNER GROUP

P.O. Box 519

N-1612 Fredrikstad

Norway

www.sleipnergroun.com

Made in Norway

